

The Ministry

DECEMBER, 1961

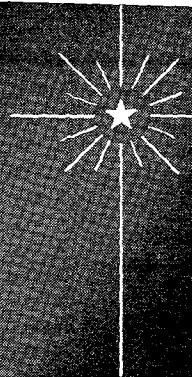

*"The star-steeped hills
Heard David sing
'Thy staff, thy staff
And rod—'
Look Gabriel,
Shepherds
Hurrying
To find the Lamb of God!"*

—Arni Oetell



The Tireless Stars

Roll on, O tireless stars, roll on,
In silent splendor roll;
Whisper to man upon the sod
Of Heaven's divine control.

And all your flashing glories speak,
Your viewless pathways shine;
Till to the finite sons of clay,
"Our Maker is divine."

Roll on, and gild earth's darkened scene
With light that is divine:
Dimmed through ages past and gone,
Still in your glory shine.

Defiant of all cumbering years,
Fearless of sin's rude blast,
Shine, glorious stars of light, shine on
Till earth's dark night is past.

Then in a splendor newly born
Regild the darkened scene,
Till heaven's glad myriad worlds forget
That sin has ever been.

Roll on, O tireless stars, roll on;
Tell with a voice divine,
"The God who gave us being still
In splendor bids us shine."

—Robert Hare

Sa

S

O

Thir
burn
Sab
Linc
assi
ther
Lon

Spe
are
Dej

YO

The Ministry

Official Journal of the Ministerial Association of Seventh-day Adventists

VOLUME XXXIV

DECEMBER, 1961

No. 12

Editor

ROY ALLAN ANDERSON

Associate Editor

ANDREW C. FEARING

Managing Editor

HARRY W. LOWE

Assistant Editors

E. EARL CLEVELAND
WALTER SCHUBERT

Copy Editor

J. INA WHITE

Consulting Editors

REUBEN R. FIGUHR, WALTER R. BEACH,
EDWARD HEPPENSTALL, LOUISE C.
KLEUSER, W. B. OCHS, H. L. RUDY

Art Editor

T. K. MARTIN

Circulation Manager

WALTER SCHUBERT
E. EARL CLEVELAND, *Assistant*

Overseas Contributors

GEORGE BURNSIDE	Australia
ERWIN BERNER	Central Europe
J. R. SPANGLER	Far East
H. J. WESTPHAL	Inter-America
WAYNE E. OLSON	Middle East
ODD JORDAL	Northern Europe
ENOCH OLIVEIRA	South America
S. G. MAXWELL	Southern Africa
J. F. ASHLOCK	Southern Asia
G. CUPERTINO	Southern Europe

Editorial Office: 6840 Eastern Avenue, NW.
Washington, D.C.

Printed and published monthly for the Ministerial Association of Seventh-day Adventists by the Review and Herald Publishing Association, Washington, D.C., U.S.A. \$4.00 a year; 40c a copy. Add 25c for yearly subscriptions to countries requiring extra postage. Second-class postage paid at Washington, D.C.

DECEMBER, 1961

IN THIS ISSUE

EDITORIAL

Ministerial Reflections H. W. Lowe 4

ARTICLES

A Fruitful Field Often Neglected R. R. Figuhr 5
The Covenant of Works O. T. Allis 6
Fellowship (Bible Word Studies—No. 5) ... R. E. Loasby 9
The Greatest Internship K. A. Wright 12
"Never Lose Your Sense of Urgency" R. H. Pierson 16
"What Think Ye of Christ?" W. Farag 18
Church Leadership and Leaders C. G. Tuland 21
The Incarnation—Its Deeper Meaning ... E. E. Roenfelt 24

REGULAR FEATURES

Some Books I Can Recommend K. A. Elias 15
Research:
"Who Is Sufficient for These Things?" ... M. S. Nigri 27
Evangelism:
Some Airatorium Problems Solved R. E. Dunton 30
Bible Instructor:
Our Friends the Methodists L. C. Kleuser 32
Books for Your Library 42
News 44
Pulpit—Pointers for Preachers 48
Index for 1961 37

POEM

The Tireless Stars 2

Our Cover

"We have seen his star . . . and are come to worship him" (Matt. 2:2).

Prophecy became history that night! The "Star out of Jacob, and a Sceptre . . . out of Israel" had appeared (Num. 24:17). Gentiles had begun to come to the light, and "kings to the brightness of thy rising" (Isa. 60:3). Mary had sung her hymn "My soul doth magnify the Lord" (Luke 1:46), because God had fulfilled His covenant of mercy "to Abraham, and to his seed for ever" (Luke 1:55). Zacharias had prophesied, "Blessed be the Lord God of Israel; for he hath visited and redeemed his people" (Luke 1:68).

The passage of time cannot alter the fact that the Incarnation marked the beginning of the end in God's plan for the redemption of mankind. That is much more significant to believers at this season than is a Christmas feast to the worldling.

Cover Picture: Arlo Greer, Artist

Page 2. Harry Baerg, Artist

EDITORIAL

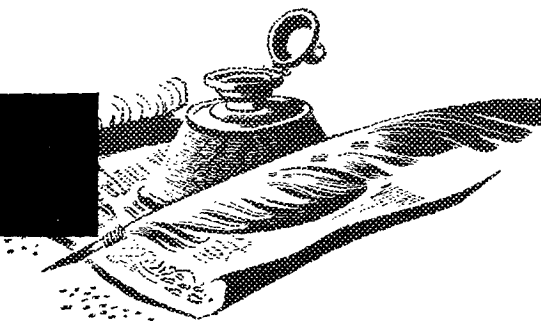

Ministerial Reflections



MINISTERIAL reflections at the end of another year might well center in a simple interrogation: "How many people did I bring face to face with the Lord Jesus Christ during 1961?"

Whether we are administrators, teachers, writers, evangelists, pastors, Bible instructors, or lay leaders, this is a question of the first magnitude. A man may not see much tangible evidence, either because his ministry is peripatetic, and therefore he does not have the same congregation for measurement of results, or because he may minister through his pen, in a classroom, or in some administrative office. Nevertheless, every man ordained to advance the gospel—and we know of no other kind of ordination—is a custodian of the souls of men.

We are all both watchmen "unto the house of Israel" and God's spokesmen "to warn the wicked from his wicked way" (Eze. 3:17, 18). Our real business is epitomized by Paul thus: "Him we proclaim, warning every man and teaching every man in all wisdom, that we may present every man mature in Christ" (Col. 1:28, R.S.V.).

Every branch of Christianity in time becomes cluttered with machinery, and the machine can become a purely mechanical, impersonal, deadly thing. The one sure way to suffuse the mechanics of our work with thrill and with life-giving and life-perpetuating power is to see in every man a soul for whom Christ died, and to see ourselves as Christ's witnesses. It is not enough to be a bookkeeper, a secretary, a treasurer, an editor, a chairman of this or that. We become men whose chief busi-

ness is to confront men with Jesus Christ.

Someone rushed without knocking into my office one day, and I was on my knees praying with someone who had consulted me about great spiritual and domestic problems. Afterward the colleague who blundered into the room said to me: "You have time in your busy schedule for that?" I said: "If I didn't, I could not regard myself as a minister of the gospel." Two years later the man I counseled with said to me: "Pastor, I think that heart-to-heart talk and that prayer in your office saved my home from going on the rocks and brought me back to God!" I realized anew that every man can help souls and in that sense be a soul winner, if he wants it that way. "It is better to help our friends to recover lost grace than lost money," said Thomas Aquinas.

There is a word of challenge to all, and especially to those engaged directly in ministerial service in this passage:

To the minister of the gospel God has given the work of guiding to Christ those who have wandered from the narrow way. He is to be wise and earnest in his efforts. At the end of each year he should be able to look back and see souls saved as the result of his labors.—*Testimonies*, vol. 8, p. 17.

This fading year will provide infinite satisfaction to the man who can look back to some men, women, youth, and children set upon the heavenward road through his ministry. Statesmen and scientists are afire with the desire to send a man to the moon. We should be on fire to set men on the road to the kingdom of God. The drudgery of traveling from place to place, the tedium of discussing, pleading, and praying with wayward men, disappears in the consciousness of souls redeemed.

The conversion of souls to God is the greatest, the noblest work in which human beings can have a part.—*Testimonies*, vol. 7, p. 52.

The greatest work, the noblest effort, in which men can engage, is to point sinners to the Lamb of God.—*Gospel Workers*, p. 18.

This question of interesting ourselves in the salvation of men is really the center of every devotional service for our Master.

The purest and most elevated devotion to God is that which is manifested in the most earnest desires and efforts to win souls to Christ.—*Testimonies*, vol. 3, p. 187.

In this context, better than the words *effort, labor, energy*, is the word *passion*, meaning "love on fire." Unworthy passion degenerates into hatred, jealousy, sin; fire-filled spiritual passion is that indescribable something seen in the life of our Lord Jesus Christ. There was about Him what has been called an inflammatory touch, which reined men up sharply and brought them face to face with eternal realities. There was about Him both light and heat, whereas most of us have light enough but no heat. He was so full of divine passion that He could say: "The zeal of thine house hath eaten me up," or, "Zeal for thy house will consume me" (John 2:17, R.S.V.).

The visual image of zeal as Coleridge calls it, is a boiling pot. The root of the word is in the Greek *xeō*—to boil. Could there be a more vivid word to describe the boiling over with heat of the passions and emotions of the Son of God. . . . The one thing that Jesus could not endure was ease in Zion.—CHARLES L. GOODSELL, *Cyclopedia of Evangelism*, pp. 21, 22.

One of the tragedies of Christendom is its waning spirit of evangelism. There is a growing indifference to the condition of men's souls, and this shows itself in spineless preaching. Preachers who have little or no faith in the Word are less and less concerned about human destiny. The blazing sun of preaching that brings sinners face to face with God is sinking into night, and, as others have trenchantly said, "Moonlight preaching ripens no harvest."

To be sure, we face a new age, and every form of spiritual shepherding and soulsaving are more difficult than ever before. But God prepares men for every age, and such men are always utterly dedicated, unselfish, unsparring, like the Master who emptied Himself.

We must be more decidedly in earnest. . . . Mark how all through the word of God there is manifest the spirit of urgency, of imploring men and women to come to Christ.—*Testimonies*, vol. 6, p. 65.

It was said of John Wesley that "he was out of breath pursuing souls." When men are consumed with that kind of passion they can look back at the end of each year and see souls brought to the Lord Jesus Christ.
H. W. LOWE

A Fruitful Field Often Neglected

R. R. Figuhr

President, General Conference of Seventh-day Adventists



THE names of 12,368 interested people were sent to pastors and evangelists in 1960 by the Voice of Prophecy and Faith for Today. These people had, for weeks and months, been listening to and looking at our radio and television programs. They had been enrolled in our Bible correspondence schools and had finished the courses. In many instances they needed but little additional help to get them across the line. According to reports, of these 12,368 only 5,027 were visited in the fields. It is good to know, however, that not all the remaining 7,341 were neglected. A large number of these have also been reached, though not reported, and not a few have been brought into the church. But, sad to say, this is not true of all. How many were not visited no one can say—one could guess probably around 5,000.

It is tragic to think that such a large number of interested people were not cared for. It is sad to think that even one person who is interested in the truth is passed by. Here is an excerpt from the letter of such a one. It is a pathetic story, related in the person's own words:

"I finished the course and have my diploma. I liked the teaching very much. In answer to the question, Would you like to have someone visit you? I answered Yes, but no one came. I was longing to become a member of some church. Had someone called on me at the time I was studying your lessons, I might have been a Seventh-day Adventist today."

This woman did become a member of a church, but not the Adventist Church!

There is no more promising field for souls than that among those who have been studying in our correspondence schools and following our programs over

the air. It is a continuously enlarging field. Yearly we spend many thousands of dollars to keep these programs and schools going.

It is done for just one purpose—to eventually win people to Christ and to His truth. Let us not neglect this fruitful field.

The Covenant of Works

OSWALD T. ALLIS

[This challenging article appeared in *Christianity Today*, July 31, 1961. Those who are familiar with the writings of Dr. Allis will need no further incentive to read it. As a former professor of Old Testament history and exegesis at Westminster Theological Seminary, Philadelphia, Pennsylvania, the author is writing out of a very full background. The areas touched upon are wonderfully well handled. We are confident that our readers will appreciate this clear setting forth of a basic doctrine.—R. A. A.]

WHATEVER else the statesmen and economists of today may report to us, they cannot say, "We have walked to and fro, through the earth, and, behold, all the earth sitteth still and is at rest." The earth is not sitting still; it is not at rest. Recent years have been marked by constant change, accompanied by turmoil and confusion. Many foundations have been destroyed; and the question is asked anxiously, What can the righteous do? What of the future?

As we look out on the world, we can hardly fail to see that the great problem which confronts us is that of *authority* and *obedience*. It faces us at every level: personal, domestic, social, religious. Is man an autonomous anarchist? Or is he a responsible being; and if responsible, to whom?

The Bible has a simple but comprehensive answer to this question. Briefly stated it is this: Man was created by God and in the image of God; and the duty which God requires of man is "obedience to his revealed will." The authority of God, implied in His Creatorship, has as its correlate the obedience of man; and God's will is revealed in the Bible.

That this is so is the Bible's constant claim. It is plainly set forth in the account of the creation of man. Five imperatives are at once laid upon man (Gen. 1:28); and three times the word "commanded" is used of God's dealings with Adam and Eve. The story is briefly and simply told. God commanded; Adam and Eve disobeyed; the penalty or sanction attached to the command was invoked, and the guilty pair, under sentence of death, were driven forth from the presence of God.

The relationship established in Eden has been properly called the covenant of works. That it promised life as the reward of obedience is not immediately stated. But it is made abundantly clear elsewhere, notably in Deuteronomy (6:5; 10:12 f.; 30:15-20). The First Psalm is a poetical expounding of this covenant; and it has its counterpart in Romans 2:7-9. The penalty of disobedience is shown in the mournful cadence in Genesis 5, "and he died," and in the terrible judgment of the Flood which destroyed "the old world of unrighteousness." The consistent teaching of the Bible is that "the wages of sin is death."

The covenant was made with Adam in a state of innocence; and almost his first recorded act was the breaking of it; and human history from that day to this is a tragic record of man's failure to keep it. Consequently, in the plan and purpose of God, the covenant of works was immediately followed by the covenant of grace. This covenant is first set forth cryptically in the words of the protevangel (Gen. 3:15) which promised Eve ultimate triumph over the enemy of her race. In this covenant the emphasis is on faith. This is made clear in the wonderful words that are said of Abram: "And he believed in the Lord; and he accounted it to him for righteousness" (15:6), to which Paul appeals to show that Abraham was justified by faith and not by the works of the law. He also appeals to the words of the prophet, "the just shall live by faith" (Hab. 2:4). The New Testament abounds in statements which justify Luther's challenge to Rome—"justification by faith alone." John 3:16; Acts 16:31; Romans 2:8 are a few of them.

Since these two covenants are often contrasted rather sharply as works *versus* faith, it is important to remember that the basic requirement of both is exactly the same. They both require *obedience* to the revealed will of God. This is made especially clear in the life of Abraham. Abraham is Paul's great example of salvation by faith.

But no mere man was ever more severely tried and tested in the school of obedience (Gen. 22:18; 26:5). In the great faith chapter in Hebrews we read that when Abraham was called to go forth to the unknown country he "obeyed; and he went out, not knowing whither he went." This whole chapter should not be called "the faith chapter" but the chapter of "the obedience of faith" (Rom. 16:26). For of all its examples of faith it can be said, "They climbed the steep ascent of heaven through peril, toil, and pain."

By the covenant of grace the Christian is not offered faith as an easy substitute for works of righteousness. It offers him an unmerited and unearned righteousness, the righteousness of Christ received by faith, which challenges him and demands that he walk worthy of his high calling, that he learn to say as Paul did, "the love of Christ constraineth us" (II Cor. 5:14). The fact that he is not under the law as a basis of works-salvation does not set before the Christian a lower standard than that of the Mosiac law, but a far higher one; and this for at least four reasons: (1) Being made free from the curse and bondage of the law as a covenant of works, he ceases to be a servant (slave) and becomes a son, a member of the household of God. (2) He has set before him the perfect pattern of obedience in the person and work of Christ. (3) He is given the strongest motive for loving and obedient service, gratitude to Him who died that he might live. (4) He has received the indwelling of the Holy Spirit to illumine, sanctify, and energize him for the willing and obedient service of God. When Jesus gave His disciples a new commandment, "As I have loved you that ye also love one another," He set them a standard of obedience that surpassed the commandment of the Law, "Thou shalt love thy neighbor as thyself." Little wonder then that Paul answers the question, "Do we then make void the law through faith?" with the emphatic words, "God forbid: yea, we establish the law." And the great Catechisms of Protestantism—Luther, Heidelberg, Westminster—devote much space to

delineation of the meaning of the Decalogue as setting forth what Tyndale called "the obedience of the Christian man."

Since then it is clear that the Gospel does not abrogate the moral law as a standard of life and conduct but raises it to a higher level both by example and precept, it is not surprising that various efforts have been made from New Testament times until now, by carnally-minded Christians—and none are wholly dead unto sin—to set aside the covenant of works as of obligation to the Christian, or to modify its demands. Space will permit only brief discussion of the most important of them.

Antinomianism. This heresy was met with already by Paul. Stating the antithesis between faith and works in the most absolute fashion, "Shall we continue in sin that grace may abound?" Paul gave it the conclusive answer, "God forbid. How shall we that are dead to sin, live any longer therein?" The whole teaching of the New Testament is that justification has as its objective sanctification, redemption from all iniquity. A faith which does not bring forth fruit unto righteousness is not a living faith. The bandit who comes secretly to the priest for confession and absolution only that he may with a quieted conscience return to his life of thievery and violence is like the Jews of old who made the Temple "a den of robbers," a refuge against the consequences of their evil deeds.

Perfectionism. This is the opposite extreme. It not merely recognizes the duty of man to do the will of God, but insists that he is able to do it. It has its familiar illustration in the Pharisee who thanked God that he was not as other men and took pride in his good works. And the lesson of the parable is that all self-righteousness is an offence in the sight of God. This teaching must either lower the standard of obedience, or minimize the corruption of man and his consequent inability to obey God perfectly. This is illustrated most clearly in the doctrine of the church of Rome. It teaches that baptism removes the guilt and corruption of man's nature and that prevenient grace is given him to enable him to

NOBLE

¶ It is a noble and great thing to cover the blemishes and excuse the failings of a friend; to draw a curtain before his stains and to display his perfection; to bury his weaknesses in silence, but to proclaim his virtues on the housetop.—South.

Old Adventist Pamphlets Wanted

Our research committee is interested in reaching members who may have old SDA pamphlets for which they have no particular use. We wish to acquire these publications purely for reasons of study, and not for the purpose of resale. We are interested in pamphlets written at the time of the Battle Creek days, any pamphlets by or about A. T. Jones, or concerning the Minneapolis Conference of 1888 and other historic events. We should appreciate hearing from anyone possessing such literature, since we are planning to keep such a collection in our research library.

H. W. LOWE

do the will of God. The extreme form of this teaching is supererogation, that man can do not merely all that God requires but more, that by special acts of obedience (celibacy, poverty, austerity) he can lay up additional merit, which the Church can administer, for the benefit of sinful members of the body of Christ. This teaching makes the super righteousness of the saints (the few) the means of saving sinners (the many) from the torments of purgatory. It has no warrant in Scripture.

Perfectionism is taught in various forms in Christian churches today. It is biblical and sound when it recognizes and stresses the demands of Scripture for perfect obedience to the will of God. It is mistaken and dangerous when it fails to recognize that "no mere man since the fall is able in this life perfectly to keep the commandments of God, but doth daily break them, in thought, word, and deed." The Apostle Paul confessed that he had not "already attained." But he said, "I press to the mark to the prize of the high calling of God in Christ Jesus." Anyone who thinks he has *attained* deceives himself. Everyone who does not *press toward the mark*, fails to realize the obligation of his high calling.

Dispensationalism. This popular teaching is characterized by the dividing of biblical history into a series of distinct and contrasted dispensations. The most important are: *promise, law, and grace.* It teaches that the dispensation of promise was introduced by the Abrahamic covenant, the sole requirement of which was faith, that obedience was not required until at Sinai Israel "rashly accepted the law" (Scofield). The fallacy of this teaching can be shown in several ways. (1) Abraham's faith was proved by his obedience when he was called upon to offer up Isaac (Gen. 22:1-

18), and the blessings promised him and his seed were given "because thou hast obeyed my voice" (cf. 26:5). (2) Dispensationalists admit that the promise to Abraham was conditional when they tell us that to be or to remain in the land was a *condition* of blessing. (3) Refusal to accept the law at Sinai with its promise of blessing would have been an act of disobedience, which would have been dealt with as severely as was the refusal to go up to possess the land (Num. 14:26-38).

Barthianism. The primary emphasis in the crisis theology, of which Karl Barth is the most distinguished representative, is placed on the transcendence of God. This was the natural reaction to the immarantism of the old liberalism. It holds the separation between God and man to be utter and absolute. God must break through to man, if man is to know God redemptively. This breakthrough or "crisis" is an act of revelation and it is made in and through the Scriptures. But according to Barth the Bible is not a divine and infallible book but a very human and fallible book. It is not the Word of God: it contains it. It is only as God speaks through it to the human soul that the written word becomes God's Word to the individual man; only if the word "finds" him is it God's Word for him. Let us illustrate from the Decalogue. Suppose the command, Honor thy father and thy mother does not "find" the adolescent of today, what power has Barthianism to require him to obey it? The great peril in Barthianism is its subjectivism. If man's knowledge of God and His will comes only through the Bible, then only a fully dependable Bible can give man the clear and certain knowledge which he needs. But the Barthian must first decide for himself what the will of God for him is before he is under any obligation to accept it. Thus every man makes for himself his own "covenant of works" and does that which is right in his own eyes.

Existentialism. Like Barthianism, existentialism, despite its great popularity, is a relatively new teaching. It is traced back to Kierkegaard, who in revolt against the spiritual coldness and lethargy of the Danish State Church, placed the emphasis on personal decision as against what has been aptly called the "spectator attitude" toward life.

This has developed into a tendency to

reject the authority of all external standards and codes. It involves such familiar ideas as that of the sophists that "man is the measure of all things." It may be atheistic or theistic.

An extreme form of it is found in the attempt of Bultmann to demythologize the Bible. Since the supernatural does not appeal to the "scientific" man of today, does not *find* him, it is treated as myth and eliminated, which means of course the denial and rejection of any divine authority or sanction in the Bible or elsewhere.

Centuries ago in a time of distress in Israel, a prophet of the Lord promised the people deliverance from Shishak. But he added these impressive words in the name of the Lord: "Nevertheless, they shall be his servants; that they may know my serv-

ice, and the service of the kingdoms of the countries." Freedom is a great word today, a word to conjure with. The Bible speaks in terms of service—service to God, servitude to man. It pictures the glory of the one, the misery of the other. Let us hope and pray that the trials through which men are passing today in their struggles for self-expression and for liberty, may lead them to submit themselves in loving obedience to Him of whom alone it can be said that His service is perfect freedom.

Bibliography: The Westminster Confession and Catechisms; H. Witsius, The Economy of the Covenants; general works on systematic theology, such as those of C. Hodge, A. A. Hodge, A. H. Strong. Of recent works: C. F. H. Henry, Christian Personal Ethics; Contemporary Evangelical Thought (ed. by the same); Scofield Reference Bible; O. T. Allis, Prophecy and the Church; A. Reese, The Approaching Advent of Christ; monographs in the Modern Thinkers series: A. D. R. Polman, Barth; S. U. Zuidema, Kierkegaard; Satre; H. Ridderbos, Bultmann.

Bible Word Studies—No. 5

Fellowship

R. E. LOASBY

Professor Emeritus, Andrews University

ONE of the loveliest words in the Christian's vocabulary is *fellowship*. It means participation, sharing, community of interests, companionship. This is expressed in the New Testament by a whole group of words, but owing to the required shortness of this article, I can merely introduce but one of them. This one is *koinōnia*. This term is used by Plato for co-education; it is a favorite expression for the marriage relationship as the most intimate between human beings. A man and a woman enter into marriage in order to have *koinōnia*, that is, to share everything in life together, whether joy or sorrow, whether illness or good health, whether wealth or poverty.

This feminine abstract noun is used twenty times in the New Testament, and is translated in the King James Bible "fellowship" twelve times, "contribution" once, "communion" four times, "distribution" once, "to communicate" once, and "communication" once. In addition to this noun we have *koinōneō*, a verb used eight times in the New Testament; *koinōnikos*, an adjective used once; and the noun *koinōnos*, "a sharer, partner," found ten times.

For one's encouragement to study all

these terms that express various phrases of fellowship, we shall consider in some detail examples of *koinōnia*, beginning with our relationship with the Godhead.

The apostle John speaks of the fellowship between workers and then adds that this fellowship is "with the Father, and with his Son Jesus Christ" (1 John 1:3). He is telling the believers that they may have what the apostles have. This wonderful sharing is one of the fruits of accepting the gospel of Christ. This fellowship is not possible for those who are in darkness (verse 6), but it is so close with the child of light that John literally says, "God continues to abide in him, and he in God" (1 John 4:15). Such verses as these suggest the unity of the Godhead; also it is in the person of the Son that God bridges the chasm that sin caused between Him and mankind. The use of the preposition *meta*, "with," by John in 1:3 of his first Epistle stresses the separateness of the three persons, even as the *koinōnia* emphasizes their unity. Christ is truth and light in concrete form, and it is only as we walk in the light that we enjoy this fellowship. The possibilities of blessings for the believer that stem from it are simply breathless.

In particular relation to the Son let us consider the following: The apostle Paul in 1 Corinthians 1:9 speaks of the Father as trustworthy, reliable, and he places that word (*pistos*) in the emphatic position in the Greek. He then states that the Father calls us into fellowship with His Son, Jesus Christ our Lord. It should be realized that the apostle is not here speaking of fellowship or communion in spirit with Christ, but of actual participation in Christ's Sonship. This is, of course, a participation that opens the door to countless sharings with Christ, such as being joint heirs with Him (Rom. 8:17), and being like Him as sons of God (2 Thess. 2:14; 1 Peter 4:13). The main thought here is sharing even now many of the privileges of sonship. That is the wonder of this objective genitive construction here: "that fellowship that belongs to His Son, Jesus Christ our Lord." This is a collective participation and union that does not depend on our faithfulness but is fully guaranteed by God's trustworthiness. This fact is the basis of Paul's joy and hope; it is also the basis of ours.

The third Person of the Godhead. The apostle Paul names the three persons of the Godhead in 2 Corinthians 13:14 in pronouncing a benediction, again an intimation of the three persons' unity. In this

benediction he speaks of the communion of the Holy Ghost, thereby intimating that whoever has the fellowship of the Holy Spirit has also the grace of Jesus Christ and the love of God.

This is the most complete in wording and meaning of all the benedictions written by Paul, owing in part, one would think, to the wretched party spirit and contention that had plagued the Corinthian church. So the apostle speaks of the graciousness toward us that comes from the heart of Jesus Christ, of the love of God that must fill and inspire the believers to walk in His ways, and then that sense of realization of partnership with the Holy Spirit, which unites the church as members of one Body. Then the apostle adds "with you all," so that none is left out. This verse not only definitely suggests the tripersonality of the Godhead but also thereby informs us that our blessings from above are threefold; so also our fellowship with God is threefold.

In Philippians 2:1 the apostle continues and expands his exhortation of chapter 1:27. He states four motives to stress and inculcate Christian duties. In chapter 1:27 he speaks of the believers' conduct—that it should be a brave standing up (*politeuesthe*) for the gospel of Christ in a spirit of union; that is, that disposition of mind which animates the true child of God. Now he expands this in chapter 2:1. He speaks of the encouragement of which Christ is the source; of the comfort that flows from love; of the fellowship with the Holy Spirit—a partaking of His gifts and strength; then, of tender emotions and understanding.

Always the manner of Christian fellowship is determined by the particular context of each reference. This is particularly important for an understanding of those references that speak of *koinōnia* between brethren, and this fellowship always denotes a relation between persons, based on Christian unity (Eph. 4:4). There is a *koinōnia* that is a sharing of friendship, deep inward regard for others. This is spoken of by Luke in Acts 2:42, stating that the three thousand converts who were added to the church by one stroke were continuing steadfastly "in the fellowship." This is a fellowship of the believers, one with the other: no inward hard feelings, but a proper Christian regard for one another's rights, privileges, and welfare.

Editorial Notes

We have a number of inquiries for back numbers of the **MINISTRY** magazine, particularly from workers who desire complete annual sets. These inquiries seem to be prompted by the fact that we are preparing a detailed index for our journal since its inception in 1928. We have been a little delayed in that work, but it is proceeding and will appear in due time. Persons having complete sets they are willing to part with might communicate with us first so that we can put them in touch directly with the people concerned.

When we offer mimeographed material, whether in the form of articles that have already appeared in the **MINISTRY** or entirely new material, we aim to provide one copy for each reader, as we have no funds for wholesale distribution. Many requests have come for material on the "Radio Church of God." Those requiring more than one copy may get them from us at cost, which is 15 cents for the set of three, amounting to 23 pages of material.

Evangelists using black light may be interested in a full set of charts and one black-light unit, used only once, valued at \$175, available through this office at less than half price. H. W. L.

The apostle Paul speaks of expressing this fellowship in an objective, practical way, a "practical sharing," motivated by their fellowship. Three times he uses the term *koinōnia* in connection with taking up a collection for the poor believers in Jerusalem. This is Christian fellowship expressed as a practical thing. The three texts are Romans 15:26; 2 Corinthians 8:4; 2 Corinthians 9:13. Hebrews 13:16 speaks of the same kind of privilege: "to communicate forget not" (K.J.V.), but more literally, "forget not fellowship," and it means precisely that.

He is incapable of a truly good action who finds not pleasure in contemplating the good actions of others.—Lavater.

The apostle is exhorting the believers in respect to their various duties, and telling them to carry out all these in a spirit of fellowship. One duty spoken of in Romans and Corinthians is taking up the collection for the mother church, which had been experiencing hard times. This collection was a public duty or service (*leitourgēsai*, a term used of a public service in Romans 15:27). The *koinōnia* was *not* the collection, but emphatically the spirit of fellowship that was the motive behind the taking up of the collection, a motive that set forth the inward unity of the church, and which was indeed the noblest characteristic of the whole transaction.

The apostle speaks of "fellowship in the gospel" (Phil. 1:5). He is extremely happy and thankful to God for the Philippian, and the prayer of thankfulness he directs to God each time he thinks of them is based on their "fellowship in the gospel." That is, fellowship in personal faith on Christ as the Saviour and Mediator, fellowship in worship, fellowship in proclaiming the truth to others, and when occasion should arise, undoubtedly real spiritual fellowship expressed in willingness to contribute to the expense of the gospel work.

The apostle speaks of "the fellowship of the mystery" (Eph. 3:9), which has been hidden in God from the ages. This "mystery" in the New Testament does not mean the mysterious as in the English word, but that which is outside the range of natural apprehension, and can only be realized and appreciated by divine revelation. It is that which is made palpable in a manner

and time appointed by God, and only to those who are controlled by His Holy Spirit; it is the mystery that has been hidden from the ages and generations of the past, but is now revealed to the saints (Col. 1:26). It is used of spiritual truth generally as revealed in the gospel (1 Cor. 13:2). The apostle's preaching unfolded this mystery in the full light of revelation, i.e., the Gentiles to obtain the gospel; and with that, spiritual truths generally with the union of redeemed men with God in Christ. One of Paul's privileges was "to enlighten" (*phōtīsai*, "to make see" K.J.V.) all men in respect to fellowship in this mystery now revealed by God. This is a unity in the body of Christ.

There is a particular fellowship in the sacrament (1 Cor. 10:16). The apostle speaks of the cup upon which the minister asks a blessing, and the bread which the minister breaks, and states these emblems are a means of our fellowship, our inward union in a participation of the benefits of Christ's sacrifice on the cross. These emblems are *a means* of our living, vital union with Christ. The cup and the bread are not said to be the blood and body of Christ, but a fellowship (*koinōnia*), a joint participation of the blood and body. It should be noted that the apostle does not say "the fellowship," for that would imply the sacrament was the only means of fellowship; so he says "a fellowship," namely, one that is sacramental, a real participation in the benefits of the crucified body and shed blood of Christ for justification and forgiveness of daily sins.

Reflect upon your present blessings, of which every man has many, not on your past misfortunes, of which all men have some.—Dickens.

The other great fellowship terms of the New Testament present a wide field of Christian sharing. They speak of a fellowship between men simply because they are men. There is a fellowship in material things, fellowship in experience, a joint ownership in business, in responsibility. There is no group of words in the New Testament more gracious than these of fellowship in glory, in pain and tears, in things divine and human.

This Biblical fellowship theme takes its beginnings from the name *Jehovah*, which admittedly expresses life in its continuance

(Continued on page 34)

The Greatest Internship

KENNETH A. WRIGHT

Stewardship Secretary, Florida Conference

It is always a distinct pleasure to participate in an ordination service where a father and son are concerned. It does not often happen, but surely no father could ever wish for a happier occasion than that which permits him to preach the sermon or give the ordination charge to his own son.

Recently I was privileged to have a part in such an ordination. The sermon was preached by Elder Kenneth A. Wright, now stewardship secretary of the Florida Conference, but formerly president of Southern Missionary College. His message to his son and two other young men, former students of his upon whom he had previously conferred Bachelor of Arts degrees, will be read with appreciation, as will their responses. On such occasions God can speak to the hearts of men and women, and all present were deeply moved.

R. A. A.

ELDER LEISKE, it was very thoughtful and generous of you to extend to Mrs. Wright and me the gracious invitation to come to the Alabama-Mississippi Conference and have a part in this mountaintop experience in our lives as parents—the ordination of our son Walter to the gospel ministry. I hope you will pardon me if I seem informal or even paternal, for in reality all of these three young men are my boys, inasmuch as it was my privilege as president of Southern Missionary College to grant them diplomas and confer degrees upon them at the completion of their ministerial course. To confer a degree is an honor, but it does not and cannot compare with the honor of participating in the ordination to the gospel ministry in the remnant church—the greatest honor that can be bestowed upon a man by this denomination.

Young men, you have acceptably served your internship, and you have been recommended by your conference and union conference committees as being worthy of ordination, which will make the preaching of the everlasting gospel your chief and life work. While you have already demonstrated your ability and burden for bringing souls to a decision for Christ, your real ministry is just now beginning.

As you come down from this mountain-

top experience of the hour you will find there are deep and rugged valleys and plains nearby that you and all your members must travel. A lesson from the greatest pastor-internship on record may help you. I refer to the relationship of Moses and Joshua. Read carefully Numbers 27:18, 23. Just who was this young man Joshua, other than being the son of Nun? The Bible records of his life and activities for God provide volumes that I urge you to study in relationship to what is needed to make a faithful and successful ministry.

Joshua must have inherited from this man called "Nun" a tough and rugged moral fiber. You will remember that this same young man, Joshua, was one of the twelve men selected by Moses to spy out the land beyond the Jordan. You will remember that his story and Caleb's were distinctly minority reports, which took much courage to render—so much, in fact, that God had to intervene to save their lives from the wicked mob of fearful and rebellious people.

God realized that Joshua, naturally a man of courage, would often need super-courage, and the first chapter of the book of Joshua tells how He prepared him for his work, even to giving him a formula for success. Joshua 1:8 is the only text in the entire King James Version of the Bible where the word *success* is found, and it is completely based on meditation and obedience to God's book of the law. This, my dear young men, is the first prerequisite for success in your chosen profession. You must study and study and study, and meditate on what you have studied! The best time to do it is early in the morning before the cares and duties of the day press in.

Again Joshua sets you the example. Many times the Bible says of him, as of our Saviour, he "rose early in the morning." Carefully study the full text of the great experiences of Joshua's life: before crossing the Jordan, Joshua 3:1; before taking Jericho, Joshua 6:12; before finding and punishing Achan in his own camp,

Joshua 7:16. Each of these major events was preceded by "Joshua rose early in the morning." Build a pattern of early-morning Bible study, meditation, and prayer if you would be ready for the day's journey. However, I would repeat a word of caution authored by the wisest man who ever lived. Please be quiet about it and avoid the implications of the "loud voice" rising early in the morning mentioned in Proverbs 27:14.

It is quite possible that you will be called upon by your conference president or committee to attempt hard assignments. Ever keep in mind that one on God's side is a majority and that His biddings are enablings. God will do for you what He did for Joshua. He will magnify you, if necessary, in the eyes of your people. "On that day the Lord magnified Joshua in the sight of all Israel; and they feared him, as they feared Moses, all the days of his life" (Joshua 4:14). I was once called by the Southern Union Committee to follow Clifford A. Russell as educational and Missionary Volunteer secretary for the union, and later to follow Denton E. Rebok at Southern Junior College, and I know how inadequate a man can feel in his attempt to fill such illustrious shoes. But God keeps His promises, and Philipians 4:13 came to my rescue.

The last acts of this greatest of all interns are no less inspiring. In a proper and God-fearing way, Joshua, now an old man, spoke for himself and his family (Joshua 24:14, 15). Any minister of the gospel worthy of the name must have the support and respect of his family. And now at the conclusion of a life of leadership, courage, and inspiration, what greater recommendation or epitaph could possibly be penned than the inspired record in Joshua 24:31? "And Israel served the Lord all the days of Joshua, and all the days of the elders that overlived Joshua, and which had known all the works of the Lord, that he had done for Israel."

Keep in mind that the most basic principle in all the world was voiced by Jesus in the Sermon on the Mount as recorded in Matthew 7:12: "Therefore all things whatsoever ye would that men should do to you, do ye even so to them: for this is the law and the prophets." Satan views this ordination service with scorn and hatred, but how happy and thankful we are that Jesus has conquered Satan.

NOTE: As chairman of the Collegedale Elementary School and Academy, Elder Wright signed his son Walter's eighth grade and academy diplomas. As president of Southern Missionary College he presented his college diploma and conferred his Bachelor of Arts degree. As an ordained minister he performed the wedding ceremony at Walter's marriage to Ruth Carter. And now he has signed his ordination certificate.

Personal Testimonies Given by the Candidates at the Above Ordination Service

MY FATHER is six feet tall and wears a size ten shoe. As long as I can remember I have wanted to be six feet tall and wear a size ten shoe. However, I am five feet eleven, and wear a size nine and one-half shoe. Even though I may not be his equal physically, I do want to be like him spiritually, because I believe that dad has been a real credit to the cause of God.

Dad mentioned the fact that Joshua served an internship under Moses. Elisha also served an internship under Elijah. You will recall that just before his translation, Elisha asked his friend what favor he might do for him, and Elisha requested a double portion of Elijah's spirit. The desire of my heart is that I might have a double portion of my dad's spirit.

I feel tonight that I have had the smallest part in making this service possible, because there are others whose encouragement and counsel have contributed to this moment. I would like to express my gratitude to a loving heavenly Father, to His Son Jesus, who cared that I was in a lost condition, and to the guidance of the Holy Spirit; to my mother and dad, my sister and two brothers, to my wife and children and to my wife's parents, to my fellow ministers, and to many of you here tonight. I owe a debt of gratitude for your words of encouragement, for your counsel, and for your prayers.

My parents have been an example to me in integrity, in personal standards, and in courage. I have heard my dad repeat Philipians 4:13 many times. Paul wrote, "I can do all things through Christ which strengtheneth me." Dad believes that promise, and it has had a big influence in his life. A word of appreciation is due more for a Christian home. The best possible training was provided.

Brother Tompkins mentioned that he had never spent a day in public school. The only day I spent in public school was for an assignment from one of my classes at Collegedale. In our home we were given an example of personal religious principles.

Perhaps you have heard of overprivileged preachers' children and the fact that only the best of music, the best of associates, and the best literature was available for us. Because of his work for God, dad has traveled extensively. Our privilege to accompany him has enabled us to make friends in many places as well as to learn more of our own country. One of the greatest blessings through the years has been that many of the leaders in God's cause have been guests in our home. As far back



Left to right: Elder R. A. Anderson, Elder M. E. Loewen, Elder and Mrs. J. O. Tompkins, Elder and Mrs. W. F. Wright, Elder and Mrs. T. H. Bledsoe, and Elder L. J. Leiske.

as I can remember I have heard of the advance of our work around the world.

I solicit your prayers for Mrs. Wright and myself that we might grow spiritually and have a closer walk with God. We want to be an asset to God's cause. It is our desire to lead others to Christ. Elder Anderson mentioned the privilege and the responsibility for winning souls to Christ, and we want to be soul winners in His cause. I want to bear a positive message. It distresses me when I hear people say they wish they would be saved, or they hope they will be saved. I believe, Elder Anderson, that it is our privilege to *know* that we shall be saved. "Beloved, now are we the sons of God." Jesus said, "This gospel of the kingdom *shall be* preached . . . for a witness unto all nations; and then shall the end come."

With your continued prayers and by the grace of God the line shall not break where we stand.

WALTER F. WRIGHT



TONIGHT I'm very grateful and thankful to my heavenly Father for having led me to this hour. I love soul winning. I love the lost, and I dedicate my life to preaching this last warning message to a perishing world. I believe that we should be in earnest about this message. One hundred and sixteen years ago the judgment began in heaven. This is the truth that should give urgency to our messages. We are the only people on earth preaching this message and yet it is the most important that can be preached at this hour.

A number of years ago a man was selling fruit on a market in Tampa, Florida. As he was standing there another man approached and a conversation started. The man with the fruit was asked where he was from. When he replied, his customer asked, "Have you ever been to the big tent on such-and-such a street and listened to that preacher explain the Bible?"

"No, I haven't," said the fruit salesman.

"Then please go," said the other, "for that man explains the Bible better than any other man I've ever heard."

A few weeks later the fruit salesman went and took his family. There was the big tent with a large banner over the front—"The Bible Made Plain." The man preached on the 2300 days and the judgment. This was the first Seventh-day Adventist sermon this family had ever heard. Here was a man who knew the Bible and could explain it. They went night after night and finally were baptized—thirteen from one large family.

That fruit salesman was my dad. He had an urge to preach, and so he moved to one of our schools to finish his high school work. However, the task was great, for he had a family to care for. He urged me to study for the ministry and I really received the call of the Lord. But one day in my middle teens I came home from visiting a neighbor. Dad was working on a chicken house and asked me to help him. He began to unload his heart, for I had been falling into bad company and was fast losing my way. When he began to point out my errors, I grew very angry and spoke some cutting and harsh words. There was silence for a

moment. Looking up I saw my dad weeping for only the second time in my life. He spoke to me then in tears, telling me of his finding this truth and of his struggle to enter the ministry. He pointed out his age and the long road ahead, and said, "Son, I had to stop my struggle to enter the ministry and was in great hopes that I could lay the burden on you and have you take my place, if it was God's will. Now you are going astray and talk to me like this."

This broke my heart. I went into the house and wept bitterly. I surrendered my all to the Lord for service at that time. I'm thankful to my parents for the great gift of knowledge of this truth and a Christian education. I'm thankful to my wife for her patience and help to make this night possible.

When I first entered the ministry I wrote to the evangelist who had baptized my folks. I needed help to know how to win souls. I told him that he was my spiritual father and pleaded for help. He replied immediately with much instruction, including his syllabus for a soul-winning course, which he taught in the Seminary. After closing his letter he added a postscript: "Please read Philippians 1:6. 'Being confident of this very thing, that he which hath begun a good work in you will perform it until the day of Jesus Christ.'" That great soul winner was J. L. Shuler. May God help me to yield to Him so fully that He may complete the work begun in me so long ago on the fruit market in Tampa, Florida. Pray for me that the Lord can use me to win many souls.

JOEL O. TOMPKINS

I HAVE looked forward to this occasion for sixteen years. The call of God to work in His vineyard came to me early in life. When I was eleven years of age I attended a complete series of evangelistic lectures. At the close of these lectures I was baptized into this truth. The evangelist held a special service in which he asked all the young people preparing for baptism to come to the altar. We were asked to write on a slip of paper what we had chosen for our lifework, and a consecration prayer was offered. The Holy Spirit had impressed me on several occasions that I should prepare for the ministry, but I had plans of my own. I wrote on the slip of paper the profession I had chosen for myself, and placed it on the altar. But God's Spirit spoke to me so strongly that I took back the paper on which I had written, and on another piece of paper wrote that I would dedicate my life to the ministry.

The years that have followed that experience have proved to me that it was indeed God's Spirit that spoke to me that day.

I wish to pay tribute to my parents, whose devoted sacrifice made it possible for me to receive a Christian education. Also to my wife, whose faithfulness and devotion have constantly been a source of encouragement.

Acts 26:19 records Paul's words to King Agrippa. He was able to stand with clear conscience before the king and say that he had not been disobedient

to the heavenly vision he had received on the Damascus road. I want my life and my service to be such that with clear conscience I can stand before the King of kings and testify that I was not disobedient to that heavenly vision which I received sixteen years ago.

Pray that God may use me in whatever way He may choose, and that He may always find me willing to be used in His service.

THOMAS H. BLEDSOE

SOME BOOKS I CAN RECOMMEND

Kenneth A. Elias

President, Welsh Mission

Holiness, Bishop J. C. Ryle, D.D., J. Clarke & Co., Ltd., London, 333 pages.

This is one of the finest works on this subject I have ever read. Bishop Ryle, an Anglican, could well have been an Adventist. He deals with sin, justification, and sanctification in a practical and detailed way that cannot fail to help the serious student. The author was a deep student of the Word, and his writings reflect the Puritan theology of the seventeenth century, of which he was a great authority. This book is highly recommended to all our workers as an inspiring approach to a topic on which we lack so much today. It deserves a wide circulation indeed.

Wonderfully Made, A. Rendle Short, M.D., F.R.C.S., Paternoster Press, London, 159 pages.

The author, professor of surgery in the University of Bristol, seeks, in language the layman can follow, to set out the wonders of the human body, and through them to demonstrate the obvious fallacy in the "blind chance" theory so often propounded by the evolutionist. Although we cannot always agree with Dr. Short's conclusions, he does provide us with valuable material in the fields of physiology and embryology, which will help us in the constant battle re human origins.

The Reformation, Principal Lindsay, D.D., LL.D., T. & T. Clark, Edinburgh.

Professor of church history in the United Free Church College, Glasgow, the author traces the Reformation story in Germany, Scandinavia, Switzerland, France, the Netherlands, Scotland, and England. He concludes with a scholarly analysis of the principles of the Reformation. His style is at once authoritative and readable, and this book should be most helpful to all who wish to have concise information as to the why's and wherefore's of this fascinating and vital period.

"Never Lose Your Sense of Urgency"

(Concluded)

ROBERT H. PIERSON

President, Southern African Division



URGENCY must characterize our *preaching* as well as our *planning*. Paul's message to Timothy, "Never lose your sense of urgency" (2 Tim. 4:2),* was given in context with "preach the word;

... reprove, rebuke, exhort with all longsuffering and doctrine" (2 Tim. 4:2). Urgent times demand urgent preaching. It is of the utmost importance that a preacher of the Advent should not "take the hour" or "occupy the pulpit." We stand between the living and the dead, and our preaching must constantly remind our congregations that soon there shall "be time no longer" (Rev. 10:6).

"If our gift is preaching," Paul wrote, "let us preach to the limit of our vision" (Rom. 12:7).* I learned a valuable lesson early in my preparation for the ministry. I pray that God may never let that lesson grow dim in my thinking. Fresh from conquests in the realm of sports, I had a great deal to learn when the Lord called me to preach the Advent message thirty years ago. A kindly teacher of speech began my "education" the first few days in college when he informed me I was one of the poorest prospects in public speaking he had ever had. This fatherly enlightenment comes to my mind frequently. I am reminded that if I ever accomplish anything in the pulpit it is because of God's help. With most of us, blessing comes to those who sit under our ministry in spite of, not because of, the human instrument. Preaching that saves is a gift from God.

Remembering this, inspired Paul challenges us, "Let us preach to the limit of our vision." We must be the most effective preachers the great Shepherd of the flock can make of us.

What is "the limit of" the "vision" of an Adventist preacher? It is the measure of our message. That message includes such stimulating, challenging themes as righteousness through faith, a finished work, the time of trouble, the latter rain, the shaking,

the loud cry, the close of probation, the falling of the plagues, the coming King, a life that measures with the life of God in a sinless, sorrowless, deathless world. What other group of Christian preachers have been commissioned to herald such an all-inclusive, thrilling evangel? We are indeed preachers for eternity. As such, urgency must characterize our every discourse; therefore "let us preach to the limit of our vision."

How sad that in such an hour God should find some of us asleep at our posts. "Many who have been placed upon the walls of Zion, to watch with eagle eye for the approach of danger and lift the voice of warning, are themselves asleep. The very ones who should be most active and vigilant in this hour of peril are neglecting their duty and bringing upon themselves the blood of souls."—*Testimonies*, vol. 5, p. 234.

God has called us to be watchmen on the walls of Zion. "O son of man, I have set thee a watchman unto the house of Israel; therefore thou shalt hear the word at my mouth, and warn them from me" (Eze. 33:7). "If when he seeth the sword come upon the land, he blow the trumpet, and warn the people" (verse 3).

He has placed us there "to watch with eagle eye for the approach of danger and lift the voice of warning" as we meet the perils of the last days. If we do our work faithfully, the Lord declares us guiltless of those who fail to heed our warnings. "Then whosoever heareth the sound of the trumpet, and taketh not warning; if the sword come, and take him away, his blood shall be upon his own head. He heard the sound of the trumpet, and took not warning; his blood shall be upon him. But he that taketh warning shall deliver his soul" (verses 4, 5).

Some, however, the Lord declares through His messenger, who "should be most active and vigilant in this hour of peril are neglecting their duty." They are not preaching "to the limit of . . . [their]

vision." The results? They are "bringing upon themselves the blood of souls." "But if the watchman see the sword come, and blow not the trumpet, and the people be not warned; if the sword come, and take any person from among them, he is taken away in his iniquity; but his blood will I require at the watchman's hand" (verse 6).

Our preaching must be characterized by an urgency in keeping with the lateness of the hour and the solemnity of our responsibility.

It is well on occasions for us to consider how the Lord used and blessed some of the mighty preachers of yesteryear. I was arrested by this vivid description of Finney's preaching as described in S. L. Brengle's little book, *The Soul Winner's Secret*, pages 48-49, "When through him [Finney] the violated law spake out its thunders, it did seem as if we had in truth 'come unto the mount that might be touched, and that burned with fire, and unto blackness, and darkness, and tempest, and the sound of a trumpet, and the voice of words.' But when he spoke of Christ, then indeed did his 'doctrine drop as the rain, and his speech distil as the dew, as the small rain upon the tender herb, and as the showers upon the mown grass.'"

Most of us will never be able to preach like Finney. Most of us are very ordinary men, but *we do not preach an ordinary message!* When an ordinary man preaches a most extraordinary message "to the limit of . . . [his] vision," the Spirit of God can transform his halting imperfect speech into arrows of righteousness directed straight to the heart of needy sinners and halting saints.

Of Martin Luther it is said, "The energy of his faith poured forth in torrents of fire on their frozen hearts."—D'AUBIGNE, *History of the Reformation*, p. 125. There was urgency in Luther's preaching. The vision the future Reformer received as he climbed the Scala Sancta on his knees sent him forth not only as a bearer of a creed but as the herald of a passion. The religious world of his day was shaken to its foundations because a poor German monk pro-

claimed his urgent message of present truth "to the limit of . . . [his] vision." The religious world of our day must also be shaken to its foundations by God's message of present truth, which will prepare the way for our coming King. That message will not be proclaimed by one famous preaching star like the great Reformer, but by thousands of spirit-filled "little" men all over the world preaching a big message "to the limit of . . . [their] vision."

Of Jesus in His day it is said, "They were amazed at his way of teaching, for he taught with the ring of authority" (Mark 1:22).^{*} This is but another way of saying there was a ring of urgency in His preaching. It is said that Christ saw in every person with whom He came in contact a soul for whom He was to give His life. This lent to His preaching a spirit of urgency.

The one great obsession of our Saviour's ministry was to "finish his work." "Jesus saith unto them, My meat is to do the will of him that sent me, and to finish his work" (John 4:34). This passion filled His preaching with a dynamic urgency.

What is dearer to the heart of an Adventist preacher than the hope of seeing the work finished? We talk about it. We sing about it. In almost every prayer we plead for it. We preach about a finished work. In our ministry, as in that of our great Example, should not this finished-work obsession lend our preaching a sense of urgency? Should not the sight of unsaved masses around us in every land inspire us, as burdened apostles of righteousness, to preach with an earnestness and an urgency commensurate with the hour in which we live? Only such preaching will change "a finished work" from trite terminology into glorious reality.

Jesus, the Gospel writers tell us, spoke straight to the people in His day. The Saviour dwelt upon practical themes. His was plain, pointed, practical preaching. Those whose minds were not closed by blind prejudice knew what He was talking about.

I once heard a budding young preacher speak from the Gospel of John, chapter

FAITH

¶ Faith is not trying to believe something regardless of evidence. Faith is daring to do something regardless of consequences.

twenty-one, verse three. His emphasis was laid on the words "And that night they caught nothing." After listening to him speak for a few minutes I was convinced his text was well chosen. There was no hesitancy in his speech. Indeed, on occasions his fluency reached the heights of near eloquence. He "took with him words." There was only one problem. He, like the disciples, "caught nothing." When he sat down, neither I nor, I feel sure, the ap-

proximately one hundred other persons in the congregation, knew what he had talked about. Instead of speaking directly to us with a message of urgency he dwelt in the stratosphere of oratory. Often his thread of thought was obscured by his pearls of speech. He indeed "caught nothing."

Jesus spoke straight to His people. The messenger of the Lord counsels us to do likewise. "I urge upon you who minister

(Continued on page 35)

"What Think Ye of Christ?"

(Concluded)

WADIE FARAG

Evangelist, Nile Union

The Trinity



ALTHOUGH the term "Trinity" is not scriptural, the concept it expresses is certainly Biblical. In the Scriptures we note that there are three distinct persons in the Godhead: the Father, the Son, and the Holy Ghost.

The Trinity, or Godhead (Acts 17:29; Col. 2:9), is not three gods but one God in three persons. "The Lord our God is one Lord" (Deut. 6:4) is a truth not only taught in the Old Testament but in the New (Mark 12:29; 1 Cor. 8:4-6; Eph. 4:4-6).

This doctrine is certainly inscrutable, yet not self-contradictory. It represents God *not* as three distinct gods (tritheism), or as three persons united in *one person*, or as a trinity of forms or manifestations that are not necessary in an eternal trinity in the divine nature, as Sabellius taught, but it represents God as three distinct persons that are one in nature. This triune monotheism is incomprehensible to finite beings because there are no analogies to it in the human experience. Man, poor finite man, can never fully fathom the Infinite, whether in his concept he be a solitary Being or a triune God as revealed in the Bible. Here again it should be reiterated that the doctrine of the nature of God is not to be discussed from the viewpoint of what is comprehensible to man, for man cannot comprehend the Omniscient One, but rather from what is revealed.

The words of Paul in 2 Corinthians 13:

14, "The grace of the Lord Jesus Christ, and the love of God, and the communion of the Holy Ghost, be with you all. Amen," known now as the apostolic benediction, together with the words of Jesus, "Go ye therefore, and teach all nations, baptizing them in the name of the Father, and of the Son, and of the Holy Ghost" (Matt. 28:19), provide the most complete, explicit, and clear summary of the doctrine of the Trinity. These "three living persons of the heavenly trio" (*Evangelism*, p. 615), the Father, the Son, and the Holy Ghost, are spoken of in the Scriptures as distinct persons, each of whom is recognized as God, each of whom is eternal and possessing the same attributes, and yet they are one in essence and are equal. The following are some verses substantiating this:

John 6:27: "Which the Son of man shall give unto you: for him hath God the Father sealed." Here the Father is named God and is distinguished from the Son.

John 1:1: "In the beginning was the Word, and the Word was with God, and the Word was God" (cf. Gen. 1:1). Here the Father is distinguished from the Son and is called God. The Son also is called God. They are both equal and eternal.

Psalms 2:7: "Thou art my son; this day have I begotten thee." Father is distinct from the Son.

John 14:16, 17: "I will pray the Father, and he shall give you another Comforter, that he may abide with you for ever; even the Spirit of truth." Here the three are spoken of as distinct persons.

John 14:9, 11, 18: "He that hath seen me hath seen the Father"; "I am in the Father, and the Father in me"; "I will not leave you comfortless: I will come to you [by the Holy Ghost]." Here the three persons are spoken of as one. (See also John 17:21.)

Psalms 139:7: "Whither shall I go from thy spirit?" and the following verses. The Spirit is represented in this verse as omnipresent, an attribute of God.

1 Corinthians 2:10: "The Spirit searcheth all things, yea, the deep things of God." The Spirit is omniscient, also omnipotent. (See Rom. 15:19; Zech. 4:6; Job 33:4.)

John 1:4; John 14:6; John 5:26: "In him was life," "I am . . . the life," "hath life in himself." The Son is self-existing and self-existent.

MATTHEW 28:19: "Baptizing them in the name of the Father, and of the Son, and of the Holy Ghost." Here the spiritual gifts are attributed equally to the three persons of the Godhead, who are distinct from one another.

Acts 5:3, 4: "Why hath Satan filled thine heart to lie to the Holy Ghost? . . . Thou hast not lied unto men, but unto God." The Holy Spirit is identified as God, not rhetorically and figuratively as mortal men are identified. (See Ex. 4:16; 7:1; Ps. 82:6, 7.)

Philippians 2:6: "Being in the form of God, . . . equal with God." Father and Son are equal.

Colossians 1:17: "He is before all things." The Son is eternal.

Revelation 22:13: Jesus says, "I am Alpha and Omega, the beginning and end, the first and the last." Jehovah says in Isaiah 41:4, "I the Lord, the first, and with the last; I am he." This shows also that the Son is eternal.

1 Corinthians 12:4-6: "The same Spirit. . . . The same Lord [Jesus Christ]. . . . The same God [the Father]." Here the equality of the three is indicated.

Matthew 11:27: "No man knoweth the Son, but the Father; neither knoweth any man the Father, save the Son." Here is seen the equality of the Father and Son. This verse compared with 1 Corinthians 2:11, "Even so the things of God knoweth no man, but the Spirit of God," shows the three persons of the Trinity to be equal and each objective to the other.

John 5:23: "That all men should honour the Son, even as they honour the Father."

Persons receiving equal honor are equal.

John 14:1: "Believe in God, believe also in me," indicates two distinct persons who are equal.

John 10:30: "I and my Father are one," one not merely ethically.

John 14:11: "Believe me that I am in the Father, and the Father in me." Christ invites us to believe His oneness with the Father. Not only is the Father in Him but He is in the Father.

These are just a few of the verses that express and imply the triune nature of God.

"What Think Ye of Christ?"

Christ is God in the highest sense. He and the Father are two distinct persons, both are self-existing and self-existent, a fact that is inscrutable. They are not, however, two distinct persons and at the same time one *person*—that would be self-contradictory. Christ is one with the Father "in nature," "in character," "in purpose," "in power," "in authority," "in substance," and possesses "the same attributes" as the Father. (See *Patriarchs and Prophets*, p. 34; *The Great Controversy*, p. 495; and *Signs of the Times*, Nov. 27, 1893, p. 54.)

Because Christ is God He applied to Himself the name "I AM" of the self-existent, self-existing God. He said, "Before Abraham was, I am," thus applying to Himself the same name of the self-existent God who said to Moses that His name was "I AM THAT I AM" (John 8:58; Ex. 3:14).

Christ claims absolute oneness with the Father. He said, "I and my Father are one" (John 10:30). Because of this oneness John enunciated three great truths about Jesus in the first verse of his gospel. He emphasizes Christ's eternity, personality, and divinity. He said, "In the beginning was the Word." That is in the absolute conception of anteriority of time the Word then *was*, not that He *became*, or *was created*, but He eternally *was* in existence. "And the Word was *with* God," a separate personality eternally with God. "And the Word was God," not *was a* God, but *was in* the absolute sense God. "All things were made by him; and without him was not any thing made that was made."

"The world was made by Him, 'and without him was not any thing made that was made' (John 1:3). If Christ made all things, He existed before all things. The words spoken in regard to this are so deci-

Minister Joins Church Via Books in Library

Two factors played a part in leading George Wilson, a minister of the Advent Christian Church, to become a Seventh-day Adventist.

His search for a better understanding of prophecy took him to the public library, where he found L. E. Froom's *Prophetic Faith of Our Fathers*. In these books he not only found help in prophetic interpretation but was deeply impressed by the unified system of doctrine taught by Seventh-day Adventists.

Since he had an acquaintance with the Seventh-day Adventist pastor in the local ministerial association, Wilson's growing conviction led him to seek this pastor's friendship and suggest that they study together. The pastor, Don Martin, of Fort Myers, Florida, readily responded, and after a period of study and preparation, he had the privilege, on February 25, of baptizing George Wilson.

CHARLES R. BEELER

Public Relations Director, Florida Conference

sive that no one need be left in doubt. Christ was God essentially, and in the highest sense. He was with God from all eternity, God over all, blessed forevermore."—*Selected Messages*, vol. 1, p. 247.

In the first verses of the Gospel of John is to be found conclusive proof of Christ's divinity. It is of interest to note that Martin Luther, alluding to John 1:1, says, "The Word was God' is against Arius; 'the Word was with God' is against Sabellius." Arius of Alexandria (A.D. 325) held that Christ was created and was younger than the Father; Sabellius of Ptolemais in Pentapolis (A.D. 250) taught a trinity of forms or manifestations—not that the Trinity was eternal in the divine nature, but that God merely manifested Himself in three different ways.

The use of the word "all" in several verses with reference to Christ establishes beyond contradiction the deity of the Son. There is unmistakable assertion that He is associated with God upon equal footing, does the works of God, is omnipresent, and is worshiped as God. Note the word "all" in the following verses:

John 5:23: "That *all* men should honour the Son, even as they honour the Father."

John 1:3: "*All* things were made by him."

Colossians 1:16: "For by him were *all* things created, that are in heaven, and that are in earth, visible and invisible . . . *all* things were created by him, and for him."

Hebrews 1:3: "Upholding *all* things."

Ephesians 1:23: "The fulness of him that filleth *all* in *all*."

John 16:30: "Knowest *all* things."

Hebrews 1:6: "Let *all* the angels of God worship him."

Colossians 2:3: "In whom are hid *all* the treasures of wisdom and knowledge."

If "all" the wisdom and knowledge is hid in Christ—all of it—and if it is accepted that the Father has hid in Him also *all* the wisdom, then we have conclusive proof that Christ must be divine and one with the Father. Here is unmistakable evidence of His divinity. Similarly, it must be concluded that if Christ knows *everything*, created *everything*, is worshiped by *all*, He must be the Supreme Being—one with the Father. No created being can be thus qualified, for between God and the highest created being there is infinite difference. Either we accept this conclusion or the absurd conclusion that the Father does not have "all" in Him and therefore is inferior to the Son, a conclusion that has all evidence against it. However, accepting Christ's divinity and oneness with God sheds light on the words of inspiration: "For in him dwelleth *all* the fulness of the Godhead bodily." This fullness can never be divided; therefore Christ must be one with the Father "the image of the invisible God" (Col. 1:15), "God blessed for ever" (Rom. 9:5).

Christ said, "No man hath seen God at any time; the only begotten Son, which is in the bosom of the Father, he hath declared him." None other than God could reveal God. No created being can do that; for God is infinitely higher than the highest possible creature. Only the Infinite can reveal the Infinite. It took Jesus to reveal the Eternal One to us. This is what makes Christianity the complete and final revelation, not merely one of the conflicting competing systems, each advocating only a portion of the truth but never all of it.

It is this that makes Christianity the only religion that has no error, for it was revealed by Him who is the truth.

What a great revelation that is for you and me, and what a sacrifice it took to make it possible. Like Thomas, and writing this from Alexandria, Egypt, where the Christians sang in the second century, "One only is holy, the Father; One only is holy, the Son; One only is holy, the Spirit," I glory in saying to Jesus, "My Lord and my God" (John 20:28).

Church Leadership and Leaders

C. G. TULAND

Pastor, Illinois Conference



IN ORDER to evaluate Christian leadership we should not analyze a position or an office, but we should try to describe *men*, personalities with certain characteristics. The requirements are so comprehensive that the apostle exclaimed, "Who is sufficient for these things?" (2 Cor. 2:16). In his first epistle to Timothy the apostle enumerates the qualifications of a bishop, or as we call him, an elder (1 Tim. 3:1-7). In Phillips' translation the following words are used to describe his character—self-control, discretion, disciplined life, hospitable, gift of teaching, gentleness. There are many additional qualities which when summarized describe the sum total of a Christian leader—personality, natural abilities, intellectual capabilities and acumen, spirituality.

It seems to be quite natural that when we elect men as elders we choose such men who have a certain social standing and are gifted with some degree of eloquence, for they are not only public representatives of the church but they also should be able to express themselves in a clear and convincing manner when standing in the pulpit. Nevertheless, the question is whether these are the most important criteria on which we should make our choice.

The Personality of a Leader

Sometimes men have been chosen as leaders because of their eloquence who lacked some of the more important qualities of leadership. Moses was a poor speaker while Aaron was an eloquent man (Ex. 4:10). Yet the Biblical record indicates that Aaron did not possess the wisdom, stamina, and the moral strength required for leadership. He gave in to the demands of the people and made the golden calf for them. And when he was accused of having led the people astray, he laid the blame upon the people he should have guided in the ways of God (Ex. 32:21, ff.). It was Moses, the man

without oratorical ability, who not only had the courage to face the idolatrous masses but who also possessed the spirit of selflessness and offered his life for the wayward flock (Ex. 32:32). Strength paired with humility, resistance against evil, complete devotion to the saving of the erring—these were the characteristics of the greatest of all leaders of Israel.

Such qualities are still needed today because the leaders of the church have to preserve the unadulterated gospel. They come up against many influences and sometimes insidious teachings. There are the so-called reform movements that have to be dealt with in order to protect the church against false teachings and divisions. Such a defense has to be made intelligently, in a well-informed manner, justly, and in a Christian spirit. There are also some within the church who try to bring "new light" that is neither sound nor Biblical. The elders have to deal with such persons firmly, factually, and tactfully. Such matters have to be clarified in a brotherly and humble spirit, lest some turn away from the church, not because of the new teaching but on account of an unchristian attitude.

True leadership strives for unity. When men of different opinions and strong conviction meet in committee meetings, the qualities of a leader become apparent through the wisdom with which he deals with problems. To be able to distinguish between principle and opinion, the important and the trivial, to be willing to give up an opinion but stand firm on principle—that is true leadership. To do this without giving offense and to be willing to suffer for that which is right is also characteristic of a leader. True leaders are true Christians in the first place, men, as Ellen G. White says, "who will stand for the right though the heavens fall" (*Education*, p. 57). "God calls for men and women of stability, of firm purpose, who can be relied upon in seasons of danger and trial, who are as firmly rooted and grounded in

the truth as the eternal hills, who cannot be swayed to the right or to the left, but who move straight onward and are always found on the right side."—*Testimonies*, vol. 4, p. 75.

The Natural Abilities of a Leader

What are the natural administrative abilities of a leader? Determination to impose his will upon committees and congregations? Such an attitude is wrong, and we do well to heed the admonition of the apostle Peter when he says that elders should not be domineering (1 Peter 5: 1-3). Twenty-five years ago I was assigned as translator to Elder J. L. McElhany, in the case of a rebellious minister in Hungary. Never have I seen a leader of this denomination reaching out for the soul of an erring man with so much gentleness and at the same time, notwithstanding his wrong views, with so much Christian determination.

The leader's capacity is best expressed in his relationship to his fellow workers and his congregation. No man should ever expect uniformity of opinion among all in all matters. Diversity of opinion can be and should be made a cause of fruitfulness and advancement of the church. But it should never cause division. The ability of working together with men who know their own minds and have plans or methods shows the maturity of a man.

Again, a man is a true leader if he succeeds in gaining the cooperation of the congregation in accepting and carrying into effect the plans of the church. As Seventh-day Adventists we frequently do some hard driving. Our denomination is continually involved in one campaign or another, to the extent that it appears sometimes to be burdensome even to those who are most willing to contribute. It takes wisdom and understanding to make the spiritual emphasis predominant even in material things. Thus a true leader must know how, and to what extent, he can urge his flock. An episode from Jacob's life will illustrate this point. When he had made peace with his brother Esau, he declined to rush his caravan, saying, "My lord knows that the children are frail, and the flocks and herds giving suck are a care to me; and if they are overdriven for one day, all the flocks will die" (Gen. 33:13, R.S.V.). The care for the flock, the spiritual welfare of the church, is still the greatest respon-

sibility of both the minister and the elder.

It is easy to lose our sense of values in our race for goals. We can easily lose balance in religion when we judge the church by achievement instead of spirituality—the leaders or ministers by their success in Ingathering, by their performance instead of by their motivation, by their activity instead of by their spirit.

We are living in a world that has greatly changed during the past fifty years. These changes had their effect upon the church, its position, its administration, its policy, and its finances. Ministers and elders have become organizers, administrators, builders, and committee chairmen. Though these things are an addition to their duties, they should in no wise influence their concern for the spiritual growth of the church.

Let the term "officer" not be misunderstood, for though a man is an elder or officer, he is not a commander but a man endowed with the gift and the spirit of a shepherd. It takes more of deep human understanding, patience, capacity to bear and to endure the frailties of humanity, in order to be a successful leader than it requires pure intellect or administrative know-how. Although intelligence and natural ability are necessary in leadership, they are by no means of greater value than the spiritual quality of a Christian man.

The Intellectual Capabilities and Acumen of a Leader

We are living in an age when knowledge has tremendously increased as foretold by prophecy. Unfortunately, we as a people do not always measure up to our own preaching. Too often we stand before the congregation with old "warmed-up" sermons of yesteryear, or a collection of newspaper quotations, or we use the pulpit for reading exercises. Well should we remember that there is no substitute for preaching the Word of God, and that in order to do so effectively we must *study* the Bible. We must not only read it, we must dig deep, search, and increase our knowledge of it. There is more to it than archeological confirmation or speculation on the meaning of some complicated passage. The essence of preaching has most aptly been expressed by the apostle Paul in 2 Timothy 3:16, Phillips.*

All scripture is inspired by God and is useful for

teaching the faith and correcting error, for resetting the direction of a man's life and training him in good living.

And again, in order to achieve this purpose, Paul states that

The scriptures are the comprehensive equipment of the man of God, and fit him fully for all branches of his work (verse 17, Phillips).*

None of us will ever be able to fully master the Word of God. That armor will always be too big for puny man, as was Saul's armor for David. But why should we not continually enlarge our vision and our Biblical knowledge by prayerful study? Why should we not widen our understanding of its meaning by reading new and different translations?

There is also an endless stream of good books that enable one to get a better understanding of the Bible in spiritual meaning as well as in doctrine and historical setting. Preaching the Word is serious business. It will not do to pick up the Bible on Sabbath morning, place it on the pulpit, and then preach on a text found where it happens to fall open.

It is here in our most serious responsibility that most of us fail. We do not feed the sheep; we do not feed the lambs. The church of God is starved and thus unable to grow into a greater Christian experience. The worshipers never come to behold the glory of God, because their leaders fail to remember that the comprehensive equipment of the man of God also requires a comprehensive and consistent effort, a prayerful intensive study, in order to handle the Word of God effectively. There is no other way to give to the church the bread of life than to do it spiritually, intelligently, and with sound knowledge. This is the responsibility of any leader who has been called to stand in the pulpit.

The Spirituality of the Leader

But knowledge is not everything. What the most brilliant mind fails to achieve, genuine love and Christlike understanding and patience will do. There is not a single soul in this world who does not have some kind of problem. Many church members are unable to cope with their problems. There are social problems, there is sin, there are young people who need guidance, and there are older ones who seem to belong to the forgotten ones. Some have be-

Answers to Walter Martin

A new book entitled *Doctrinal Discussions* is now on the press and will shortly be published by the Review and Herald at the low price of \$2.50.

This book contains the answers to Walter Martin's book *The Truth About Seventh-day Adventism*. These answers appeared in the *Ministry* month by month for more than a year. They have been only slightly re-edited for book publication, and a chapter has been added on the various denominational views on the law of God.

We anticipate a large circulation. Order through your Book and Bible House now.

H. W. LOWE

come bitter, some self-righteous, some callous. The church elder has to meet all of these; in fact, he has to look out for them, for his work is not only in the pulpit.

We would go out too far afield if we tried to discuss the many situations where he is required to work and to act in the same spirit as our Master, with the same infinite compassion. Many years ago some of our elders "governed" through church "discipline." It may be that some use this method even today. But let us look to our Lord for guidance. Jesus loved the rich young ruler who turned away from Him. He would keep alive the smoldering wick, the waning faith, in the heart of the ruler of the synagogue (Mark 5:36).

Halfhearted Nicodemus, doubting Thomas, despairing Peter—all found in Jesus the one they could trust, to whom they could turn, knowing that He would understand. *That* is the kind of spirit people still desire to find in their leaders. The human soul yearns for understanding *today* as it did in the days of Christ.

As we search our hearts today let us confess our shortcomings as leaders of the church, and in humility and with renewed consecration let us make a new beginning in order to fulfill this task. The primitive church used a chant in the Greek language, "Kyrie eleison," meaning "Lord, have mercy upon us." Let that be our prayer, and let us believe that He will hear us and make our ministry fruitful for the salvation of His church, for the time to save His people has come.

*From *The New Testament in Modern English* by J. B. Phillips. Copyright 1958, by J. B. Phillips. Used by permission of The Macmillan Company.

The Incarnation—Its Deeper Meaning



ON DECEMBER 25 the Christian world again will be celebrating the birth of Jesus Christ, the Son of God, into this world. Students of the Scriptures and of the physical geography of Palestine, of course, are well aware that

this is not the actual date of the birth of Christ in Bethlehem of Judea. The date of His birth is not definitely known. It is known, however, that this significant event did not occur in the month of December, but that the church decreed the twenty-fifth day of December as the anniversary of this miraculous meaningful occurrence.

Although this is so, nevertheless it is good that we contemplate once again the significance of this phenomenal event and its meaning to mankind.

The simple, but inspired, record declares that Mary "brought forth her first-born son, and wrapped him in swaddling clothes, and laid him in a manger; because there was no room for them in the inn." While this was occurring, shepherds, watching their flocks in the fields surrounding Bethlehem, suddenly were startled by an angel appearing and announcing, "Behold, I bring you good tidings of great joy, which shall be to all people. For unto you is born this day in the city of David a Saviour, which is Christ the Lord" (Luke 2:7-11).

In making this announcement the angel gave to men a revelation of supreme meaning and import, for the incarnation of Christ is the most stupendous, the most significant, and the most influential fact in the history of the world. We do well to study it and ponder over it continually. What does it mean to us individually and to men as a whole?

1. *The Incarnation is a revelation of God to men.* In John 1:14 the disciple in speaking of Christ, the Word, declares that

He was made flesh and dwelt among men in order to give them a revelation of grace and truth. The purpose of this revelation was to enable men to know, to understand, and to appreciate God. "No man," says the apostle, "hath seen God at any time; the only begotten Son, which is in the bosom of the Father, he hath declared him" (verse 18).

Man in his unfallen state had the privilege and pleasure of speaking with God and of having fellowship with Him face to face. God visited Adam and Eve in the Garden of Eden and communed with them and they with Him. The entrance of sin tragically changed this face-to-face fellowship. Man in his sinful state, being unable to look into the face of God and live, was driven from Eden, and God was compelled to hide His visible presence from him.

Sin perverted man's conception of God and of His character. His mind was dark-

ERWIN E. ROENFELT

Associate Secretary, General Conference

ened and his understanding corrupted. As time proceeded and the human race became more and more sinful, God was more and more misunderstood, and soon in the mind of man He was degraded to the image that man had of himself. All the corruptions and villainies of degraded sinful men were credited to God, and soon men completely forsook their allegiance to Him.

Through the centuries of Old Testament times, God did everything that He could, by means of the revelations that He gave to men through the patriarchs and prophets, to help them to know and understand Him. A fuller revelation, however, was imperative, and this Christ came to give. Although the ineffable majesty and glory



of God had to be veiled in humanity, Christ gave to men a perfect revelation of the character of God—a revelation of His purity and perfection, His love and long-suffering, His mercy and grace, and of His transforming power. "To know God is to love Him." The mission of Christ was to bring to men this conception of Him.

Before His incarnation Christ was with God, the Father. He was the very image of His greatness, majesty, and character (Heb. 1:3). To manifest this, He came into the world. The Scriptures declare that God, who in relation to sinful man dwells in thick darkness, remote from sense and above thought, has, through the manhood of Christ, come forth to touch men. The incarnated Christ was named, "Emmanuel, which being interpreted is, God with us" (Matt. 1:23). "God was manifest in the flesh" (1 Tim. 3:16), says the apostle Paul.

The Incarnation was the expression of the truth that "God is love," a truth which by implication carries with it the divine passion, for what is love without self-imposed pain and sacrifice? He who sits upon the throne of the universe is love. He came and ministered to fallen men that we might be blissfully aware that love is wedded to omnipotence.

In the incarnation of Christ we see what God actually has done. Here we have not merely a hope or a fancy; not a vague expectation, not a promise, but an accom-

plished fact as solid and unchangeable as heaven itself. God gave His Son to become one with us and to pay the penalty for our sins that we might be reckoned His sons. This event, having occurred, does not justify any person in his indifference to God. He has given to all men a revelation of Himself.

2. *The Incarnation made it possible for Christ to share in our humanity.* When Christ was born into this world He not only came in flesh but He became flesh (John 1:14, R.S.V.). He began an altogether new mode of existence. Before coming to this earth He was wholly divine. But He united His divinity with humanity; He became man. He became what He had not been before. He not only took human bodily form but accepted its limitations as the mode and manner of His existence while on earth.

At His Incarnation, Christ did not take upon Himself the humanity of the most perfect man, but He "was made in the likeness of men," that is, in the likeness of all men—the best and the worst of men. He was made in your likeness and mine. In His humanity He shared with us in our disappointments and sorrows, in our heart-aches and griefs, in our perils and our pains. "As the children are partakers of flesh and blood," the apostle Paul declares, "he also himself likewise took part of the same. . . . In all things it behoved him to

**A Graduate Program
Leading to a
Master of Science Degree
in Health Education**

now offered through
The School of Graduate
Studies
Loma Linda University.
Ministers and teachers
are among those whose
background qualifies them
for this work.

For information regarding pre-
requisites write to:

*Chairman, Graduate Committee
Division of Public Health and
Tropical Medicine
Loma Linda University
Loma Linda, California*

be made like unto his brethren" (Heb. 2: 14-17). In all points He was tried as we are tried and tempted as we are tempted (Heb. 4:15). He was a man of sorrows and acquainted with grief. He was oppressed and afflicted, and ultimately He was brought to the end of His earthly life by the hands of wicked men in the cruelest, most humiliating death that any man has ever died.

The practical benefit of all this to us is that having experienced all the tragic consequences and results of man's sin and transgression, Christ knows how to succor us (Heb. 2:18). This Divine Being who became man is now our Mediator and constantly ministers to us the grace and the help that we need in every vicissitude of life. The exaltation of His humanity to heaven is the consolation and the source of strength of all who acknowledge and accept Him.

3. *The Incarnation has linked Divinity with humanity and heaven with earth.* One of the tragic and terrible consequences of sin is the separation that it caused between God and man. "Your iniquities have separated between you and your God, and your sins have hid his face from you, that he will not hear" (Isa. 59:2), declares the prophet. Not only did man's transgression cause a gulf of separation, but being possessed of a

carnal, sinful nature he naturally is at enmity with God. He hates the things that God loves and loves the things that God hates.

How hopeless and tragic was the condition of man! How amazing and marvelous, however, was that which God did to save him from his awful plight. In the person of His Son, He stepped down from heaven to this sin-cursed earth, took upon Himself all the weaknesses and frailties of the human family. Wonder of wonders, He did even more than that! He made Himself the substitute of all men, the substitute for you and me. And taking upon Himself our sins and condemnation, He, in His death, paid the penalty for all our guilt in order that we might be reconciled to God and God to men.

"God was in Christ, reconciling the world unto himself" (2 Cor. 5:19), said Paul. Christ came to a world that was completely out of harmony with God, a world in rebellion and revolt, a world separated from Him because of sin. After His resurrection this was a completely reconciled world. The penalty for human sin and transgression had been paid; all that now remained was for men and women individually to accept the gift and be reconciled to God.

At the resurrection of Christ from the dead, His humanity was glorified, and with that glorified body He ascended to heaven where He is now the Mediator between God and man (1 Tim. 2:5). Because of His sinless humanity He is able to bring help to the most degraded, helpless, and hopeless, with the result that man's hopes and aspirations may rise to the heights of His divinity. In and through Him all men now have the opportunity and privilege of becoming "partakers of the divine nature, having escaped the corruption that is in the world through lust" (2 Peter 1:4).

4. *The Incarnation is a revelation of the possible greatness and blessedness of man.* When Christ was born into this world, He subjected Himself to the laws of heredity. "When the fulness of the time was come," the apostle Paul states, "God sent forth his Son, made of a woman, made under the law" (Gal. 4:4). Having clothed His divinity in humanity, He was of Himself weak where we are weak and frail where we are frail. Though there was in Him a union of the divine and the human nature,

(Continued on page 36)

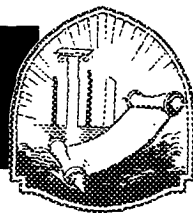

"Who Is Sufficient for These Things?"

M. S. NIGRI

President, South Brazil Union Conference



ONE of the chapters of the Bible that we have perhaps overlooked or read without a great deal of interest is the twenty-eighth chapter of Exodus. Recently I have been impressed by the lessons that this chapter contains for ministers of the gospel. It speaks of the choosing of Aaron and his sons for the priesthood, of the priestly garments, of the Urim and the Thummim, and of the golden plate upon the high priest's miter. The whole chapter contains important lessons for our ministers today.

Choosing the Priests

We read in Exodus 28:1, "And take thou unto thee Aaron thy brother, and his sons with him, from among the children of Israel, that he may minister unto me in the priest's office, even Aaron, Nadab and Abihu, Eleazar and Ithamar, Aaron's sons."

Why did God *call* men to the priesthood? We have the answer in Hebrews 5:1 to 4: "For every high priest taken from among men is ordained for men in things pertaining to God, that he may offer both gifts and sacrifices for sins: who can have compassion on the ignorant, and on them that are out of the way; for that he himself also is compassed with infirmity. And by reason hereof he ought, as for the people, so also for himself, to offer for sins. And no man taketh this honour unto himself, but he that is called of God, as was Aaron."

We see here that his principal responsibility was to act as a mediator, as a link between the holy and the profane, between God and man. In his official position the high priest was not a mere man but an in-

stitution, a symbol, an incarnation of the people, and the spiritual representative of all Israel. But why? He was to make reconciliation for the sins of the people (Heb. 2:17) and to be a mediator ministering for their sins. He was as though every Israelite was encompassed within his own being. Because of this his own attitudes affected the whole congregation; when he sinned the people sinned. Thus the entire nation participated in the consequences of his sin; his official acts were considered as though they were acts of the people. The opposite also was true, bringing blessings from Heaven upon the whole nation.

In like manner the minister of the gospel today is the high priest. "God has a church, and she has a divinely appointed ministry. . . . Men appointed of God have been chosen to watch with jealous care, with vigilant perseverance."—*Testimonies to Ministers*, pp. 52, 53.

What God expected of Aaron and his sons He expects of us today. I trust that we all may feel the weight of the souls under our care, and that we realize that we are truly separated to minister and to intercede as representatives of the people. Our concern should be like that of Bera, king of Sodom, in the war of the four kings against five, when he said to Abraham, "Give me the persons, and take the goods to thyself" (Gen. 14:21).

In his priestly functions the minister of God is not merely a man; he is really an institution, an ambassador. "Christ's ministers upon the earth . . . are appointed to act in His stead."—*The Acts of the Apostles*, p. 122. This is also what the church expects of us.

In a ministerial council held in the South Brazil Union Elder Enoch Oliveira,

Flannelgraph on Health Available

Visual aids for health education are frequently requested, and although health materials are widely available from commercial sources, they often are not the type readily adaptable in an Adventist program. Dr. Lester Lonergan, of the Loma Linda University faculty, developed the Wheel of Health, based on the true remedies of *The Ministry of Healing*. Picturing Christ as the center, the spokes radiate the principles of good health.

Warren Parmelee, a medical student at the university, has developed this idea of Dr. Lonergan's, as well as several others on health, in full-color flannelgraph sets, with art work of superior quality. A service of this type will be appreciated by every minister who incorporates health education in his evangelistic and church services. For full information on prices and materials write: Educational Arts, P.O. Box 331, Loma Linda, California.

JOYCE W. HOPP

General Conference Medical Department

ministerial association secretary of the South American Division, asked two of our laymen who were well thought of in the church to tell those assembled together what the church expects of pastors. Brother Warner Roloff, elder of the Central church in São Paulo, after counseling with four members of the church, listed forty qualities that he and his church desired their minister to possess. He said that the minister should be punctual, courteous, loving, studious, pleasant, impartial, et cetera, and ended his list by saying, "He should reveal a deep passion for souls." This passion for souls should certainly be a characteristic of a minister of the gospel. It should be his greatest concern.

The other layman, Brother Becker, elder of the Blumenau, Santa Catarina, church, spoke on what he expected in his pastor, and said as follows: "I, as a member and an elder of the church, feel greatly the responsibility that rests on me in the salvation of lost souls, and I think that your responsibility as pastor is even greater than mine, not because you receive a small compensation for your work but because the church is your responsibility. Are you truly shepherding your flock? Are you an example for them? Or is a lion within devouring your flock?"

"Our field at the present time is in great need of ministers. We have called numerous workers, but these calls have gone unanswered. Why? Why does a Christian worker turn down a call? Is it because he doesn't want to go to a more humble field

or a small city? Should he not follow the example of Isaiah 6:8? I have noticed this spirit more since I have been a member of the mission committee and have seen repeated calls for workers go unheeded. It is sometimes evident that some workers prefer to remain in more comfortable surroundings. But Isaiah did not reason in that fashion. He presented himself to God for service.

"The gospel minister should not consider so much his material conveniences or choose the best place to labor, but he should go where God calls him. The work is God's, and God will care for His workers. Isaiah asked not if he were being called to an easy or a hard field. The true pastor will sense the need to work for souls in need wherever they may be. These were the feelings of Paul as he went about his work of ministry. It is the love of Christ that should motivate us in our search for souls."

In the *Manual for Ministers*, page 14, we find this marvelous passage: "A beautiful and yet impressive designation of the representative of Christ is used by the great apostle in his letter to Timothy. There he uses the expression 'man of God.' In all his relationships he will be a man, a true man, a godly man. He will be like John the Baptist, 'a man sent from God.' He will speak for God and will be so yielded to the divine influence that God will speak through him to human hearts."

The Priestly Garments

The second verse of Exodus 28 says, "And thou shalt make holy garments for Aaron thy brother for glory and for beauty." What garments were these? For the priests there were four pieces: a tunic of white linen, linen breeches, an embroidered sash, and a headdress called a bonnet or linen turban. There were four additional pieces for the high priest—a robe with the bells and pomegranates, the ephod with two large stones, the breastplate with twelve stones and the Urim and the Thummim, and the golden plate upon the miter.

Each separate garment had symbolic significance, but together they represented the character of God; and this He wishes to see exemplified in the lives and hearts of His children (Rev. 19:8). The garments of the priests represented utility and inner purity, and those of the high priest, glory and honor. Why glory and honor? Because

the high priest, being a minister of the Most High, performed the most important act between God and His people—intercession or mediation. All heaven was continually interested in this intercession because upon it hung in balance the happiness of each Israelite. To be such a mediator was a glory and an honor.

To the high priest these garments served as a constant reminder of his holy calling as a steward of the mysteries of God. Of him the Lord expected a life entirely consecrated to His ministry. Could a greater honor or glory be given to a human being than to be a mediator between God and man? But why the finery and ornamentation of the garments? Because both the high priest and the congregation needed to be made aware of the beauty and holiness of God and the purity of their worship before the Creator (Ps. 29:2). The attractive garments of the priesthood were in themselves impressive and solemn. Picture in your mind garments shining and pure, the sixteen precious stones glittering in the sun, and the bells tinkling as the high priest moves about in his worship of God. The people are thus led to sense the beauty of holiness and the divine embellishment that comes to the life devoted to the service of God.

Today we are the high priests. "Everything connected with the apparel and deportment of the priests was to be such as to impress the beholder with a sense of the holiness of God, the sacredness of His worship, and the purity required of those who came into His presence."—*Gospel Workers*, p. 173. "The minister must remember that favorable or unfavorable impressions are made upon his hearers by his deportment in the pulpit, his attitude, his manner of speaking, his dress. He should cultivate courtesy and refinement of manner, and should carry himself with a quiet dignity becoming to his high calling. Solemnity and a certain godly authority mingled with meekness, should characterize his demeanor."—*Ibid.*, p. 172.

The High Priest's Responsibility

There is something further in this twenty-eighth chapter that has greatly impressed me, and perhaps it is the most touching symbolism of all the holy apparel of the high priest. (Read verses 12, 29, 30, 34, 38.)

Upon his shoulders the high priest bore

two stones of memorial upon which were engraved the names of the children of Israel, symbolizing that he, in addition to being responsible before God for the people, was bearing the load of their sins.

Over his heart he carried the breastplate with twelve stones, and on each one was engraved one of the names of the twelve tribes, symbolizing the love and affection that should be felt for the people. It was to be a constant reminder of his position and responsibility in the midst of Israel. Also prominent upon the breastplate were the two stones known as the Urim and Thummim—the former represented divine approval and the latter the displeasure of God. The word *Urim* means "light" and the word *Thummim* means "perfection."

Upon the head, or more correctly *upon the forehead*, as part of the miter, the high priest wore the plate of pure gold upon which was written "Holiness to the Lord." It was the most important of all the priestly apparel. The inscription was to give to the people the most elevated concept of religious worship, and to point out its supreme object. It was to show also to the high priest that his ministry should not be a mere form, but required that both he and the people enter into a complete consecration. To make religious worship a form is to bring iniquity into the worship of a holy God. God desires that we who are His high priests today learn the same lesson. The gospel ministry should not be considered by us as mere formalism. It is much more than that. It is complete dedication, without reserve, in behalf of those who are placed under our care. This is the most important lesson for our ministers to learn. Those who fail to direct their ministry and lives after this fashion are faced with the most severe condemnation of God.

It is thus that Peter counsels us in his first letter, chapter 5, verses 2 and 3: "Feed the flock of God which is among you, taking the oversight thereof, not by constraint, but willingly; not for filthy lucre, but of a ready mind; neither as being lords over God's heritage, but being ensamples to the flock." What a tremendous responsibility to act as mediators between God and man! We must carry the people in our arms! Bear them upon our hearts! Reveal to them a sanctified life! In other words, the minister of Christ must forget himself and think more of his flock. He must not shun his responsibilities and heavy burdens, but

must ever seek the welfare and happiness of God's people, understanding always that each one is of great importance in His eyes.

The inscription "Holiness to the Lord," which was always upon the forehead of the high priest as he officiated, is to serve as a constant reminder of the solemn responsibility resting upon us as the representatives of God's people.

The following experience is given in *Gospel Workers*, pages 33 and 34:

"A minister, after preaching a Bible discourse which brought deep conviction to one of his hearers, was accosted with the question, 'Do you really believe what you have preached?'"

"'Certainly,' he answered.

"'But is it really so?' asked the anxious questioner.

"'Certainly,' said the minister, as he reached for his Bible.

"Then the man broke out, 'O, if this is the truth, what shall we do?'"

"'What shall we do?' thought the minister—'we'? What could the man mean? But the question forced its way to his soul.

He went away to plead with God to tell him what to do. And as he prayed, there came to him with overwhelming force the thought that he had the solemn realities of eternity to present to a dying world. For three weeks his place in the desk was vacant. He was seeking an answer to the question, 'What shall we do?'"

"The minister returned to his charge with an unction from the Holy One. He realized that his past preaching had made little impression on his hearers. Now he felt upon him the terrible weight of souls. As he came to his desk, he was not alone. There was a great work to be done, but he knew that God would not fail him. Before his hearers he exalted the Saviour and His matchless love. There was a revelation of the Son of God, and a revival began that spread through the churches of the surrounding districts."

This is our pre-eminent need and responsibility. "And who is sufficient for these things?" (2 Cor. 2:16). "Not that we are sufficient of ourselves. . . , but our sufficiency is of God" (2 Cor. 3:5).

EVANGELISM -- Winning Men for God



Some Airatorium Problems Solved

ROBERT E. DUNTON

Evangelist, Pacific Union Conference

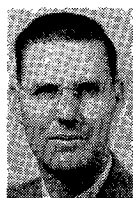

AIRATORIUMS are appearing throughout the United States as evangelists, hard-pressed to find suitable auditoriums, have turned to a space-age tent that provides a comfortable meeting place with a neat appearance and a good advertising value. But—what a task it is to shuffle, load, and unload fans, motors, furnaces, temporary electric service poles, et cetera. We thought our solution to a major part of this problem might be of help to others, so here it is.

The conference semitrailer moving van was about to be discarded. So we requested that it be given to us for permanent evangelistic use. We repaired, repainted, and put signs on it advertising "The Flight of Time" evangelistic team. But more important, we used it to save ourselves a tremendous amount of labor.

On the front of the van we installed a telescoping electric service pole, which eliminates the big chore of setting a pole for temporary service. Better consult your electric supplier for specifications on pipe size for this, and be sure to leave the bot-

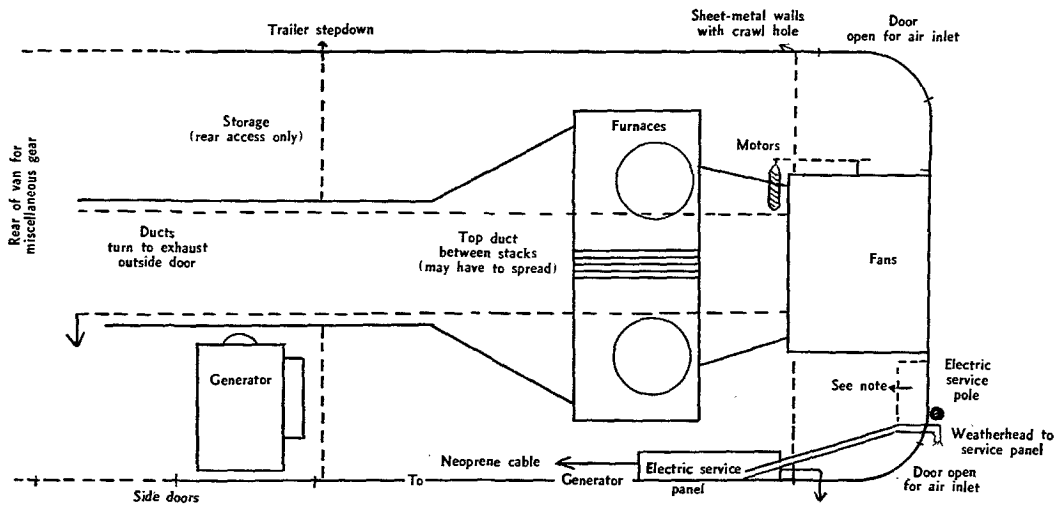

Note: Electric panel service may be located here. Air inlet doors may be screened or utilized for evaporation type air conditioning.

tom of the pipe open for drainage of smaller pipe that goes up. The main electric panels, all motor switches, et cetera, are installed inside the van. Check your local codes to be sure these are far enough away from other equipment. We have had no difficulty on this point, because the outfit is temporary and portable.

We then installed our two fans, one on top of the other in the front of the van, exhausting toward the rear. The lower fan is ducted through the two furnaces, placed side by side nearly the full width of the

trailer. We first vented them out the side, but later, for better efficiency, ran them straight up and installed removable vent caps for transit. The top fan (auxiliary) is ducted over the top of the furnace, and both curve out the side door for connection to the airatorium. Building inlets for ducts are side by side, but could be one above the other.

In our van all this equipment is placed on the "step up" (see diagram). On the main floor below the ducts we have installed our 10 KW stand-by generator and

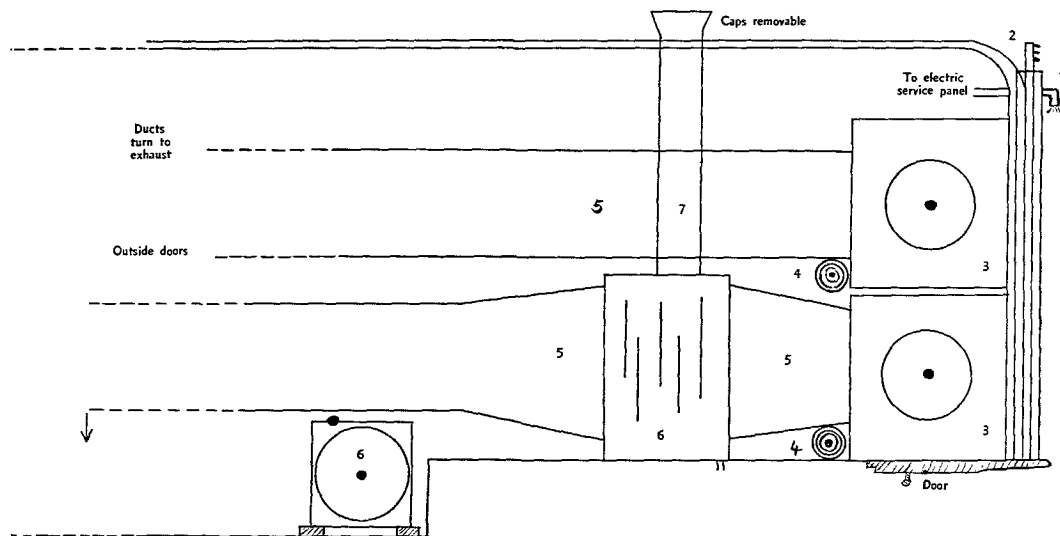

1. Electric weatherhead
2. Telescoping service pole
3. Fans

4. Electric motors (pulleys on opposite side)
5. Ducts
6. Standby generator
7. Furnace vents

auto-transfer switch. The back part of the van is entirely free for loading miscellaneous equipment.

Our breaker panels, complete with time clocks for exterior lights, signs, and furnaces, are mounted on a single panel and set inside the building, as I presume all others are. Gas connections for the furnaces inlet through the van floor. We have used asbestos and sheet-metal lining for added safety in the furnace area, and keep extinguishers handy; but we have had no need for them as yet.

When moving time arrives we load our breaker panel last, in the rear of the van, and when next erection begins we simply set it outside, plug in two cords, and everything is ready to go, independent of public power until that is connected. We usually get immediate inspection and speedy service this way.

This can undoubtedly be improved by the experts, but we did most of our own work, and beam happily about it every moving day! We hope this suggestion may ease another's task.

BIBLE INSTRUCTOR



Discussions on the Contemporary Religions of America—No. 8

Our Friends the Methodists

LOUISE C. KLEUSER



HAVING much in common with Methodism, Adventism may claim a friendly relationship with Wesleyan thinking. The Methodist revival was the third religious awakening in England. It followed the sixteenth-century Reformation and the seventeenth-century Puritanism. Historians rank the Methodist awakening of equal importance with the French Revolution and the Industrial Revolution of the century. Some claim that Wesley's preaching saved England from a revolt similar to that of France.

When Methodism was in its infancy in England morals were at a low ebb. Liquor predominated at its pastimes. Public hangings became gala occasions for the family. The idleness of the rich was in contrast with the long hours of labor of the poor. Politically and clerically conditions seemed hopeless. Rationalistic Deism was accepted by the upper class. Sermons in the Anglican Church had become vague homilies enhanced with moral platitudes. The stage was set for a revival such as the Wesleyan movement produced within the Established Church.

John Wesley (1703-1791) filled the century

religiously. He was the fifteenth of nineteen children born to Samuel and Susanna Wesley. His father's parish early initiated him in ecclesiastical duties, but it was his mother's rigid home routine—the scheduled devotions, Bible study, and service for the sick and the poor—that laid the foundation for the Wesleyan movement. During their educational program at Oxford, John and Charles, together with George Whitefield, were the leading spirits of the "Holy Club." Students had nicknamed them Methodists, for the club stressed the methodical habits learned in the Epworth rectory.

This "sick" century demanded applied Christianity in Wesleyan style. World commerce had also produced an interest in foreign missions. General Oglethorpe's colony in America, a philanthropic experiment to transplant to Georgia the poor whose debts could not be paid and for which they were sentenced to prison, had caught the missionary interest of the Wesleys. Christianizing the Indians became their burden. John Wesley's forthright spirit, however, did not fit into some of the plans of the colony and the assignment turned out to be very disappointing. Within three years he returned to England.

The Wesleys definitely came under Moravian

influence. "Depressed by his failure, he [John] returned to England in 1738 in a state of mind which has been characterized as 'conviction of sin,' from which he was led to his awakening by the tutelage of the Moravian Peter Böhler. The process involved several steps, among them being recognition that salvation is by faith alone and that it is possible by instantaneous conversion, to which was added Assurance or Witness of the Spirit and Christian Holiness or Perfect Love."—*The American Church*, pp. 314, 315.

Open-Air Preaching

In 1739 George Whitefield persuaded John Wesley to take up field preaching, for the local parishes had refused Wesley the privilege of preaching in the churches. The Anglican Church did not provide for the many people who were out of step with what the Established Church represented, so by preaching outdoors Wesley was able to reach many who were religiously untouched. But it was never Wesley's desire to break away from the Church of England. His was merely a "movement" under her protection. He had formed "societies," not churches. Groups had been brought together as "bands," and "classes" of twelve were led by laymen. It was after Wesley's break with Whitefield that Arminian theology received emphasis.

Wesley's preaching was complemented by the rare gift of his brother Charles, who became the author of more than 6,000 hymns and gospel songs. These provided for England's toilers a new joy, and men went on their way singing Arminian theology. They forgot their drab lives, and England experienced a religious awakening instead of a revolution. The influence of these ennobling revival songs continues in evangelism today.

The Spread of Methodism

Now Wesley's field preaching necessitated steps toward organizing a separate group. New converts experienced undignified persecutions, and something had to be done about it. In Bristol (1739), the cornerstone was laid for the first Methodist chapel. That same year the Foundry property in London became the headquarters of the movement. Up to 1741 Wesley had refused to recognize lay preaching, but now it became the method that actually evangelized England. The first Conference convened in London in 1744, and it became the governing body throughout the world. "Present were four clergymen of the Establishment and four of Wesley's lay preachers. The body discussed (1) what to teach, (2) how to teach, and (3)

what to do.' With the organization of the annual Conference the main features of Methodism had taken form."—*Ibid.*, pp. 315, 316.

By 1754, within ten years from the first Conference, in London alone sixteen lay preachers functioned in seven places. By 1791, the year of John Wesley's death, there were nearly 75,000 Methodists in the British Isles and many more in America. Wesley was a determined itinerant. He rode horseback a quarter of a million miles and averaged a sermon a day. His immortal words, "I look upon all the world as my parish," remain Methodism's watchword. While Wesley himself made no plans for the movement's expansion, Methodists went abroad preaching wherever they went. There was tremendous impetus in their lay preaching.

In the United States

About 1760 an Irish immigrant, Robert Strawbridge, began preaching in Maryland and four years later built a log cabin meeting-house. Philip Embury began to preach in his home in New York. Thomas Webb, "of the King's service," formed the Philadelphia Society. Then, in response to appeals, John Wesley sent two missionaries to America in 1769. Two years later Francis Asbury arrived and became the greatest figure in American Methodism. Asbury trailed and stirred the frontiersmen, outstripping Wesley's record of evangelistic fervor. He died by the side of the road in 1816.

While Methodists reached America a century and a half later than other denominations, by 1860 one third of all the Protestants in America were Methodists. Methodism had grown with the nation. But the Revolutionary War brought its problems to the church. While separation from England was obvious, the Anglican Church adamantly refused ordination for American leadership. "In 1784 Wesley made the decision which took Methodism forever out of the so-called 'apostolic succession.'"—*Ibid.*, p. 318. He set apart "superintendents" for the American movement. The ordination of Francis Asbury was declined by him in November, 1784, but he was unanimously elected by the preachers. The noteworthy Christmas Conference in Baltimore, Maryland, that same year became an event in Methodist history. It formally organized the Methodist Episcopal Church.

Wesleyan Influences

John Wesley was more than a religious reformer; he influenced important civic reforms as well. Many of England's labor leaders had been trained in the Methodist "class meetings" and were able speakers. The abolitionists of



THE
LITTLE GIANT HOTOMATIC
GAS WATER HEATER NO. 3

Will supply all the hot water needed for
Baptistries, Church Kitchens, Rest Rooms.
Heats 450 GPH, 20° rise in temperature.
Inexpensive, too.

Write for free folder. Dept. M-24.

LITTLE GIANT MFG. CO.

907 7th Street

Orange, Texas

England and America also received strength from the Wesleyan leaders who were endeavoring to stem the slavery trade. The right of the individual was a Christian doctrine that flourished richly on American soil.

Wesley had encouraged Robert Raikes, the British founder of the Sunday school, and this institution became popular when it crossed the Atlantic. Adventists also entered into the Sabbath school plan. Today, provision is made for all, from the babies in the cradle roll to the oldest grandparent. Seventh-day Adventists advocate that every church member be a member of the Sabbath school. Earle Cairns mentions in his book *Christianity Through the Centuries* the much-needed prison reforms of the Methodist, John Howard.

According to Cairns, "His [Wesley's] love of amateur doctoring led him to establish the first free medical dispensary in England in 1746."—*Christianity Through the Centuries*, p. 419. While Wesleyan "field preaching" evolved into street-meeting evangelism, best featured today by the Salvation Army, the plan took wings because of the use of gospel songs with choruses composed by Charles Wesley. These appealed to the less privileged toilers of the times. We wonder whether this method, adapted to Adventism's laymen and especially its youth, has already been exploited for the fullest results. At least we have observed in some American cities that this plan for evangelism has led souls into our message, but the work in which many Missionary Volunteers then had a part may need reviving. It has potentials for a very noble type of welfare service.

Health and Welfare Evangelism

It is inspiring to read that wonderful chapter, Isaiah 58. The eschatological prophet there includes two definite reforms for the last-day church: welfare work and Sabbath restoration. The two belong together—interrelated—before the church militant becomes the church triumphant! Adventists believe this to be a last-day prophecy, even as are those of Christ (Matt. 24:14; Rev. 14:6-12, 14).

We would invite our Methodist friends to consider that the observance of the Christian

Sabbath, the *Lord's* holy day (Isa. 58:13), bears fruitage in good works. This is not, as some would have it, legalism. In this chapter the Sabbath of Eden lost becomes the Sabbath of Eden restored. It glorifies God's sovereignty, and Christ's redemptive power. It is not the "Jewish Sabbath" of the Old Testament; it is the Christian Sabbath (rest) of the New Testament. The Sabbath is not a negative commandment; it is a positive "delight."

In the same way sanctification or holiness has an application touching spirit, soul, and body (1 Thess. 5:23). The instruction in Leviticus 11 regarding flesh foods, with its call to holiness in verses 43 to 47, has its counterpart in Paul's teaching in 2 Corinthians 6:16-18; 7:1. Neither is Adventist tithing legalism, as some of our Methodist friends sincerely believe; it is Christ's own instruction to all Christians and to the hypocritical elements of His day (Matt. 23:23). Many Methodists believe in tithing; we invite them all to receive the blessing of Malachi 3:10. Heaven will then open its windows to enable the Christian church to perform a larger welfare service, so necessary in the tragedies of earth's last days. In the developing of an expanding health and welfare work in Adventism, we have frequently been inspired toward progress by the example of our Methodist brethren. The desire to minister to the physical needs of those about us belongs in the way of holiness! The completeness of Christian character is described by John the beloved in his inviting Epistle: "We shall be like him; for we shall see him as he is" (1 John 3:2).

BIBLIOGRAPHY

- Cairns, Earle E. *Christianity Through the Centuries*. Zondervan Publishing House.
Ferm, Vergilius, ed. *The American Church*. Philosophical Library.
Holland, Kenneth. *Great Churches of America*. Southern Publishing Association.
Mayer, F. E. *Religious Bodies of America*. Concordia Press.
Mead, Frank S. *Handbook of Denominations*. Abingdon Press.
Torbet, Robert G. *The Protestant Reformation*. The Judson Press.

Fellowship

(Continued from page 11)

and actuality, yet nevertheless expressed the idea of presence to the Israelites. In talking with Moses of the name *Yahweh* the Lord was expressing a conception of relation, for existence is a relation concept. *Yahweh* is the God who is present with His people; so He said, "Certainly I will be with thee" (Ex. 3:12). Similarly the sanctuary was a place for meeting, for fellowship; and there Moses talked with God as

with a friend (Ex. 33:7-11). The prophets thought of the Temple as the meeting place of God and His people. The sixth chapter of Isaiah is a graphic word picture of this concept of God's presence with His chosen nation.

The eucharistic fellowship, so briefly spoken of above, is a continuation of this relation theme. The title "Holy Communion" presumably arises from the King James translation of *koinōnia* in 1 Corinthians 10:16, "communion." The cup and the loaf (*ton arton*) imply a fellowship, a sharing in a common salvation, and most surely suggest a unity in fellowship of one Christian with another by means of the Communion. In his sermons to the pagans the apostle must have said many things to show to his hearers the vital differences between the fellowship meals of heathenism, which were fellowshiping with demons (1 Cor. 10:19, 20), and the fellowship of the Lord's table. For Christianity is not just another religion that advocates a fellowship, but is the religion to put an end to all other religions with their fellowships, and to bring men into fellowship with Jehovah of hosts.

This brief introduction is to commend the ministry to a devout study of the group of words in the New Testament that treat of many aspects of Christian fellowship.

"Never Lose Your Sense of Urgency"

(Continued from page 18)

in sacred things to dwell more upon practical religion."—*Testimonies*, vol. 5, p. 539. The Advent message is a practical message. Preparing to meet Jesus is a practical theme. When we sit down after preaching, our people should go away knowing what we were talking about.

Marjorie Lewis Lloyd in her inspiring little book *Love on Fire*, challenges us with this solemn thought: "People do not come to church to watch a sermon go by. They come to church hoping, desperately hoping, that the sermon will get into their hearts and meet their needs and change their lives. People want to be changed. They are tired, so tired of the defeated lives they live. It is not preaching, but help that they want, and if a man can give them that help, the people will come."—Pages 42, 43.

Not just someone to "take the hour" or

to "fill the pulpit." That is not what people today want or need. They need help to discern and overcome sin in their lives. They need help to live victoriously in this evil, sin-filled world. They need help over the rough course of life's uneven journey. They need reproving, encouraging, warning, and loving! And they need it *urgently*, for the hour is late and their need is great.

"The preacher the people love most is the one who gives them the most help in daily living."—*Love on Fire*, p. 43.

With these words ringing in our ears and with God's prophetic time clock tolling the midnight hour, may God grant that a renewed sense of urgency may grip us as workers and through us God's people who long for His final deliverance. How better could I close this little message than by quoting Paul's words to Timothy as recorded in *The Amplified New Testament*:

"I charge [you] in the presence of God and of Christ Jesus Who is to judge the living and the dead, and by (in the light of) His coming and His kingdom:

"Herald and preach the Word! Keep your sense of urgency (stand by, be at hand and ready, whether the opportunity seems to be favorable or unfavorable, whether it be welcome or unwelcome, you as preacher of the Word are to show people in what way their lives are wrong) and convince them, rebuking and correcting, warning and urging and encouraging them, being unflagging and inexhaustible in patience and teaching" (2 Tim. 4:1, 2).†

May it please God to make us such preachers of righteousness!

* From *The New Testament in Modern English* by J. B. Phillips. Copyright 1958 by J. B. Phillips. Used by permission of The Macmillan Company.

† *The Amplified New Testament*. Used by permission of The Lockman Foundation, La Habra, Calif.

CLASSIFIED ADVERTISEMENTS

Advertisements appropriate to **The Ministry**, appearing under this heading, eight cents a word for each insertion, including initials and address. Minimum charge, two dollars for each insertion. Cash required with order. Address **The Ministry**, Takoma Park, Washington 12, D.C., U.S.A.

THOUSANDS OF HARD-TO-FIND AND out-of-print religious and theological books now available. Send 25c for recent catalog. Libraries purchased. Kregel's Book Store, Grand Rapids 6, Michigan.

NOW... 3 SIZES



Unbreakable . . . noise-free . . .
lightweight . . . boilproof com-
munion glasses . . . \$1.25 Doz.

FREE sample of each size

Order from
your dealer

Dept. C. 70 Pearl Street Brookline 46, Mass.

Studbury BRASS GOODS CO.

The Incarnation—Its Deeper Meaning

(Continued from page 26)

He voluntarily, for the time being, laid aside the prerogatives and powers of His divinity and met life as individual men and women have to meet it. "I can of mine own self do nothing," He said (John 5: 30). And again He declared, "Verily, verily, I say unto you, The Son can do nothing of himself" (verse 19). Christ conquered and lived victoriously and radiantly because His confidence and faith called God, the Father, to dwell with Him and in Him.

In living victoriously over sin in all of its forms and over all human besetments Christ, clothed in the likeness of sinful flesh and meeting trials and temptations as men meet them, "condemned sin in the flesh" (Rom. 8:3). Having ascended to heaven, He will now, by His Spirit, do this for everyone who is prepared to yield himself to Him and depend upon Him.

Through the Incarnation we are now able to enfold Christ to our inmost soul with a wondering, yet triumphant, sense of possession and with a trembling, yet endearing, intimacy of touch. Referring to those who through the grace of God are regarded as His saints, the apostle Paul glowingly writes, "To whom God would make known what is the riches of the glory of this mystery among the Gentiles; which is Christ in you, the hope of glory" (Col. 1:27). Yes, He dwells in our hearts, and His purpose is to reproduce Himself—the beauty of His life and the attractiveness of His character—in us.

God's ideal for our lives and our characters is, therefore, no longer an ideal that mocks, eludes, and disheartens us. It can be wondrously realized. By the fact of His dwelling with Christ while He was in the likeness of sinful flesh God has demonstrated that there is none so wicked, so low,

so outcast, or so lost, but that He is willing and anxious to dwell with that one, to help him triumph over sin, and someday to transport him to dwell eternally with Him.

At this Christmas season may the Lord help each of us as Christian workers to enter into a fuller understanding and appreciation of all that was involved in the birth of Jesus our Saviour and Lord into this world.

King James Bible Cited for Beauty and for "a Better Sense of Language"

Virtues of the King James Bible as a guide toward "a better sense of language" in a time when words and their use have assumed great importance were stressed in New York by a senior editor of the *Reader's Digest*.

Speaking to American Bible Society members holding their 145th annual meeting and commemorating the 350th anniversary of the King James Version, Charles W. Ferguson paid high tribute to that version and called it superior to more recent translations.

"A number of people have mucked about with a new translation, as our British cousins would say," the speaker remarked, calling attention to the "good deal of healthy disturbance" aroused by recent versions.

He referred specifically to *The New English Bible* and said sharply drawn "battle lines" developed as soon as it was published.

The editor conceded a "shock value" in fresh translations and agreed they can "bring out meanings hidden by familiarity."

"They have a place," he said, "but I submit as a brash layman that their place is in exegesis and not in the body of public worship. Here the resonance of the King James Version reminds the ear of the beauty of our inheritance."

"If the love of language is the beginning of wisdom in its use," Mr. Ferguson said, "the Bible can best inspire that love. No one can do more than guess" what effect better use of language can have on "the grievous circumstances in which we find ourselves."

The King James Version, Mr. Ferguson maintained, holds "means to keep us loving the language."

"What we need in the rat-a-tat-tat haste and Coney Island carelessness of American speech is to be reminded of the majesty and music of the language we have inherited." He praised the KJV for its imagery, its "tonal effects," its composition, and its rhetoric.

"The late H. L. Mencken," he said, "who wrote with professional disdain on virtually everything, including the Bible Belt, called this translation 'probably the most beautiful piece of writing in all the literature of the world.'"—*Religious News Service*.

MINISTRY INDEX FOR 1961

By Subject and Contributor

SUBJECT INDEX

- ADMINISTRATION**
 A Wise Distribution of Men—May, p. 18.
 Church Leadership and Leaders—Dec., p. 21.
- APOSTASY**
 Close That Door!—Aug., p. 17.
- ATONEMENT**
 Apocalypse and the Day of Atonement, The, Part 1—March, p. 28.
 Apocalypse and the Day of Atonement, The, Part 2—April, p. 17.
 "Priestly Application of the Atoning Act, The"—May, p. 10.
- BAPTISM**
 Baptism—April, p. 15.
 Baptismal Qualifications—Oct., p. 48.
 Large Baptism in Casa Verde, São Paulo, Brazil—Aug., p. 21.
 Largest Baptism in History of Southern Union—Jan., p. 24.
 1960 Baptisms, Regional Conferences—July, p. 33.
 Significance of Baptism, The—Oct., p. 26.
- BIBLE**
 A Commentary on the Epistle of Jude—May, p. 40.
 "Agape"—The Great Christian Virtue—Sept., p. 20.
 Baker's Bible Atlas—Nov., p. 41.
 Bible in the Making, The—Jan., p. 36.
 Bible in Thirty-two Paperbacks, The—June, p. 48.
 Bible Word Studies, No. 1—Aug., p. 11.
 Biblical Revelation and Inspiration—Feb., p. 42.
 Book of Jeremiah, The—May, p. 40.
 Children's King James Bible New Testament, The—Oct., p. 42.
 Commentary on I and II Peter and Jude—May, p. 42.
 Comprehensive Bible Concordance, The—May, p. 42.
 Dake's Annotated Reference Bible, The New Testament (with the addition of Daniel, Psalms, and Proverbs)—May, p. 42.
 Epistles to the Corinthians, The—Sept., p. 42.
 Fellowship—Dec., p. 9.
 First Epistle of Paul to the Corinthians, The—July, p. 41.
 Fourth Gospel, The—Feb., p. 18.
 Gospel Parallels: A Synopsis of the First Three Gospels—Feb., p. 18.
 Gospels Translated Into Modern English, Nov., p. 41.
 Great Personalities of the New Testament—Nov., p. 26.
 History of New Testament Times—Feb., p. 18.
 Learned Men, The—Nov., p. 26.
 Letters to Young Churches—Sept., p. 42.
 Logos and Lalia—Nov., p. 16.
 Modern Use of the Bible, The—Aug., p. 41.
 New English Bible: A Preliminary Critique, The—Oct., p. 13.
 New Testament Introduction—Feb., p. 18.
 Newberry Study Bible, The—May, p. 42.
 Principles of Biblical Hermeneutics—May, p. 42.
 Revelation and the Bible—April, p. 42.
 Ten Commandments, The—Sept., p. 19.
- Unfolding of the Revelation*—Nov., p. 41.
Wonderful Charis of God, The—Oct., p. 18.
- BIBLE STUDY**
 A God Upon Whom We Can Depend—Aug., p. 34.
 Maintaining a Successful Christian Experience—Oct., p. 32.
 Who Is a Good Neighbor?—May, p. 17.
- BIOGRAPHICAL**
Charles Wesley and His Colleagues—July, p. 29.
John Wesley—April, p. 42.
Master Preachers—July, p. 41.
- BIOGRAPHICAL SKETCHES**
 Passing of an Evangelical Leader, The—Jan., p. 39.
- BOOKS**
A Body of Divinity—Sept., p. 19.
Adventurers for God—July, p. 29.
Awake, My Heart!—Oct., p. 42.
Baker's Dictionary of Theology—May, p. 49.
Billy Graham Talks to Teeners—Feb., p. 41.
Christian Attitudes Toward War and Peace—Jan., p. 40.
Crisis in Communication—May, p. 21.
Cross Still Stands, The—March, p. 38.
Discovery of India, The—June, p. 39.
Dr. Schweitzer of Lambarene—Oct., p. 9.
For One Moment—Sept., p. 42.
God and Man in Washington—Jan., p. 36.
History of Interpretation—Aug., p. 41.
Keswick's Authentic Voice—April, p. 15.
Language, Logic, and God—June, p. 40.
Lost in the Sky—Jan., p. 42.
Metropolitan Tabernacle Pulpit, The—June, p. 11.
Miracles—Aug., p. 12.
Out of My Life—Sept., p. 42.
Philosophy for Pleasure—May, p. 21.
Problem of Pain, The—March, p. 34.
Reformation, The—Dec., p. 15.
Say "Yes" to Life—Oct., p. 42.
Seven Last Words, The—March, p. 38.
Space-Age Sunday—June, p. 40.
Standard Lesson Commentary—Feb., p. 42.
That Immortal Sea—Oct., p. 9.
Tried by Fire—July, p. 29.
Triumph of Grace in the Theology of Karl Barth, The—Feb., p. 18.
Way to Pentecost, The—June, p. 11.
Windows of Heaven, The—July, p. 42.
World's Last Night, The—Jan., p. 36.
- CHRIST**
Christ Our Example—July, p. 42.
Christology of the New Testament, The—Feb., p. 18.
 Do We Miss the Significance of Christ's Sacrifice?—April, p. 7.
 Face of Christ, The—April, p. 2.
 Jesus and the Trinity, Part I—June, p. 15.
 Jesus and the Trinity, Part II—July, p. 30.
Jesus of Nazareth—Oct., p. 9.
 Incarnation—Its Deeper Meaning, The—Dec., p. 24.
Life in the Son—Jan., p. 40.
 Life Only in Christ—Jan., p. 7.
 Son of God, the Messiah, The—March, p. 9.
 Tempted Like as We Are—Jan., p. 18.
 "What Think Ye of Christ?"—Nov., p. 18, Dec., p. 18.
- CHRIST AND THE RESURRECTION**
Death and Resurrection of Christ, The—May, p. 40.
 Did Christ Stay in the Grave Exactly 72 Hours?—April, p. 19.
- CHRISTIAN LIFE**
 Basis of Christian Belief, The—June, p. 14.
Christian Life and the Unconscious—March, p. 34.
Conscience—April, p. 15.
 Contagion of Cheerfulness, The—March, p. 2.
 Covenant of Works, The—Dec., p. 6.
 Dear Child, I Understand (poem)—Sept., p. 38.
 God's Men for God's Hour (poem)—Aug., p. 2.
Holiness—Dec., p. 15.
 Influence—May, p. 32.
 Lethargy or Liturgy—Oct., p. 48.
 Mental Reservations—June, p. 48.
 O Lord, I Came (poem)—May, p. 6.
 Off Guard—May, p. 28.
 Problem of Fear in the Christian Experience, The—Feb., p. 34.
Religious or Christian—April, p. 15.
 Some Thoughts on Eternal Life—Aug., p. 30.
 Spark That Powers, The—April, p. 48.
 "Still, Still With Thee"—July, p. 14.
 "The Church Beside the Bath"—May, p. 38.
 Victory in Christ (poem)—June, p. 2.
 Why Enoch?—Sept., p. 17.
Why I Am a Christian—April, p. 15.
- CHRISTIAN STEWARDSHIP**
 Privilege of Stewardship—Oct., p. 4.
 Stewardship and Character—Sept., p. 25.
 Tithing in the New Testament—Oct., p. 10.
- CHURCH, THE**
 Last Call to the Churches—March, p. 26.
 What Is Theology All About?—Feb., p. 4.
 Winning the Church—April, p. 48.
 Wreckers, The (poem)—July, p. 11.
- ATTENDANCE**
 Building Up Church Attendance—Sept., p. 39.
- BUILDINGS**
 Church Architecture Today—March, p. 11.
- MEMBERS**
 Helping Members to Make Their Wills—March, p. 4.
- COVER SUBJECTS**
 Christ, the Healer—Feb.
 Church and Anchor—Oct.
 Face of Christ—April
 Hands in Prayer With World Background—Sept.
 Lady With Garden Produce—Nov.
 Sailing—March
 Scene in New Hampshire—June
 Shadow of the Cross—July
 Shepherd With Sheep—May
 Two South American Girls—Aug.
 Watcher on the Mountains—Jan.
- EVANGELISM**
 By-products of Evangelism, The—Sept., p. 34.
 Conservation in Evangelism—March, p. 48.
 Evangelism and Theology—Jan., p. 19.
 Graham, Wesley, Moody—Oct., p. 48.
Great Evangelical Preachers of Yesterday—Dec., p. 42.
 "Never Lose Your Sense of Urgency"—Nov., p. 9, Dec., p. 16.

- One Lone Voice—Aug., p. 4.
 Public Evangelism and the Busy Pastor—Aug., p. 22.
 Review of Basic Principles in Approaching Non-Adventists, Part 1—May, p. 15.
 Review of Basic Principles in Approaching Non-Adventists, Part 2—June, p. 19.
 Review of Basic Principles in Approaching Non-Adventists, Part 3—July, p. 16.
 Sunday Night Meetings in New York—July, p. 26.
 Tame Talk—April, p. 9.
 What We Do We Must Do Quickly—July, p. 27.
- CHILD EVANGELISM**
 Child Evangelism Breaks Down Prejudice—Wins Adults—April, p. 28.
- CITY EVANGELISM**
 Bible Course and the Soul-winning Campaign, The—Oct., p. 28.
 Cairo Center, The—Nov., p. 24.
 Expanding Methods in City Evangelism—April, p. 30.
 Progress at the New Gallery Centre, London, England—Oct., p. 24.
- DECISIONS**
 Decision Films, The—June, p. 21.
 Evaluation of It Is Written Decision Films—Aug., p. 40.
 Psychology of Decision in Public and Personal Evangelism—Sept., p. 14.
- EXTENSION SCHOOLS**
 Andrews University Extension School at Beirut, Lebanon—Nov., p. 20.
 Andrews University Extension School, South American Division—Aug., p. 24.
 Evangelistic Leadership Emphasized in Extension School—Aug., p. 25.
- FIELD SCHOOLS**
 Evangelistic Field School at Emmanuel Missionary College, An—July, p. 20.
 Successful Seminary Field School of Evangelism, A—Feb., p. 14.
- LENGTH OF CAMPAIGN**
 Short Evangelistic Campaign, The—July, p. 22.
- LOCATION**
 Some Airatorium Problems Solved—Dec., p. 30.
- METHODS**
 Slaves or Servants?—Sept., p. 48.
- OVERSEAS EVANGELISM**
 Australasian Evangelistic Goal—Five Thousand Baptisms—Aug., p. 27.
 Evangelism and the New Africa—May, p. 19.
 Evangelism in Australasia—March, p. 24.
 Evangelism in South America—Aug., p. 19.
- SINGING EVANGELIST**
 What Has Happened to the Singing Evangelist?—Nov., p. 31.
- THE TEAM**
 Team Spirit in God's Service, The—June, p. 4.
- TV EVANGELISM**
 From TV Screen to Harvest—April, p. 24.
 How to Bring to Harvest the Screen Contacts Made by It Is Written—May, p. 24.
- YOUTH EVANGELISM**
 Thousands of Students Helped by Bible Courses—Jan., p. 34.
 Youth Can Win Souls—Oct., p. 30.
- FAITH**
 A Call to Faith—June, p. 42.
- FINANCE**
 Where Does the Money Go?—Feb., p. 30.
- FUNERAL**
 Funeral Service, The—March, p. 30.
- GENERAL**
 "All Thy Billows and Thy Waves Passed Over Me"—May, p. 2.
 Assignment: Overseas—Dec., p. 42.
 Devotional Talks for Children—Nov., p. 41.
- "From Greenland's Icy Mountains"—Nov., p. 11.
 Our Editor on the Amazon—March, p. 23.
 Our General Church Paper—Aug., p. 9.
 The True Thanksgiving Spirit—Nov., p. 4.
- GOD**
 Divine Forgiveness—May, p. 8.
 Do We Provoke the Lord to Jealousy?—March, p. 6.
 God Our Contemporary—Feb., p. 41, Aug., p. 12.
- HEALTH**
 A Vital Facet in Sickness—May, p. 48.
 Drugs and the Mind—Aug., p. 12.
 "The Missing Link"—Aug., p. 48.
 Wonderfully Made—Dec. p. 15.
- HEALTH EVANGELISM**
 Dilemma of Adventist Medicine, The—Aug., p. 22.
 Presenting the Gospel Through Medical Ministry—Feb., p. 24.
 Traffic Laws of Health—Jan., p. 31.
 "Ye Visited Me"—June, p. 32.
- HISTORY**
 Josephus, Complete Works—May, p. 42.
- HOLY SPIRIT**
 Golden Oil, The—Aug., p. 41.
 Love for the Lost—May, p. 37.
- HUMAN RELATIONS**
 How to Get Along With People in the Church—March, p. 37.
 Secret of Success—Jan., p. 48.
- IMMORTALITY**
 Natural Immortality Unsupported by Hebrew and Greek—Feb., p. 8.
 Walter Martin and the Nature of Man—April, p. 11.
- JEWS**
 Awakening Interest Among the Jews—Feb., p. 7.
- JUDGMENT**
 Hour of God's Judgment Is Come, The, Part 1—June, p. 8.
 Hour of God's Judgment Is Come, The, Concluded—July, p. 6.
- LETTERS TO THE EDITOR**
 A Minister's Wife Needs Help—Nov., p. 37.
 A Voice From the Past—May, p. 23.
 Appreciation—May, p. 23.
 Appreciation for the Ministry—April, p. 16, Oct., p. 35.
 Books—May, p. 23.
 Living Witness, The—May, p. 23.
 Retirement Problem—May, p. 23.
- MINISTER**
 A Minister Should Tell the Truth—April, p. 32.
 How Much Education Should a Minister Have?—Sept., p. 6.
 Human Problems of the Minister, The—March, p. 37.
 Making of a Minister, The—Dec. p. 42.
 Minister and Culture, The—Oct., p. 7, Nov., p. 12.
 Ministerial Reflections—Dec., p. 4.
- MINISTER'S WIFE**
 A Happy Minister's Wife—Aug., p. 38.
 Candles in the Night, No. 1—June, p. 37.
 Candles in the Night, No. 2—Sept., p. 40.
 Candles in the Night, No. 3—Oct., p. 40.
 Candles in the Night, No. 4—Nov., p. 35.
 Minister's Wife and Her God, The—Feb., p. 37.
 Minister's Wife and Her Home, The—March, p. 35.
 Minister's Wife and Her Husband, The—April, p. 34.
 Minister's Wife and the Church, The—May, p. 35.
- Preacher's Wife, The (poem)—Jan., p. 38.
 Preacher's Wife, The (poem)—Sept., p. 2.
 Shared Glory—Jan., p. 38.
- MINISTRY**
 Inspiring Young Men to Enter the Ministry—Jan., p. 22.
 Pitfalls to the Ministry—Sept., p. 9.
 Seven Keys to a More Fruitful Ministry—Feb., p. 41.
 The Greatest Internship—Dec., p. 12.
 "Who Is Sufficient for These Things?"—Dec., p. 27.
- MISSIONARY**
 Missionary's Role in Socio-Economic Betterment, The—May, p. 21.
- MUSIC IN WORSHIP**
 Humble Hymn, The—Feb., p. 35.
 Let the People Sing—Jan., p. 29.
 Minister's Ally, The—Oct., p. 34.
 Music—May, p. 26.
 Overused and Unused—June, p. 48.
- ORDINATIONS**
 1960 Ordinations for North America—March, p. 39.
 1960 Overseas Ordinations—April, p. 38.
- PASTOR**
 Ambassadorship v. Professionalism—Aug., p. 7.
 Dedicating the Church—Nov., p. 22.
 God's Pulpit—Nov., p. 6.
 "I Like Our Pastor, But . . ."—Feb., p. 33.
 Pastor at Work, The—Feb., p. 41.
 Pastor's Treasure Chest, The—Jan., p. 32.
 Planning a Year's Preaching—Jan., p. 26.
 Psychology and Pastoral Practice—June, p. 11.
 "Pure Religion . . . Is to Visit"—Dec., p. 48.
 Tale of Two Churches, The—July, p. 36.
 Work for the Deaf—May, p. 11.
- DEPARTMENTS**
 Pastor and the Sabbath School, The—Oct., p. 31.
- EQUIPMENT**
 "Bring the Books"—Sept., p. 4.
- VISITATION**
 Fruitful Field Often Neglected, A—Dec., p. 5.
 Our Forgotten Brothers—Oct., p. 21.
- POEMS**
 If the Heart Is Right—Oct., p. 8.
 Inspired by Paul—Feb., p. 2.
 Let Hearts Be Still—Jan., p. 15.
 Speaking Hands, The—May, p. 14.
 Whoso Draws Nigh to God—Feb., p. 42.
 Why?—March, p. 33.
 Winds of Fate, The—March, p. 3.
 Wishing or Fishing—March, p. 19.
- PRAYER**
 A Prayer—March, p. 40.
 A Worker's Prayer (poem)—Oct., p. 2.
 Lord's Prayer, The—Sept., p. 19.
 Moment of Truth, The—Feb., p. 48.
 Our Public Prayers—Aug., p. 5.
 Posture in Prayer—Jan., p. 14.
 Prayer—April, p. 15.
- PREACHER**
 Dare We Fiddle?—May, p. 48.
 Fresh Every Day—April, p. 48.
 Frigid Preaching—Feb., p. 48.
 Helpful Hints for Busy Preachers—Feb., p. 11.
 Inviting Death—July, p. 48.
 On Being a Preacher—June, p. 28.
 Preacher and His Work, The—May, p. 40.
 Preacher! Watch Your Weight!—July, p. 18.
 Refuge (poem)—Aug., p. 33.
 Simplicity of the Gospel, The—Feb., p. 40.
 "The Only Preaching I Can Do"—Sept., p. 48.

We Prepare and Preach—March, p. 37.
 What Makes Great Preachers?—Aug., p. 48.

PREACHING
Creative Imagination in Preaching—Aug., p. 42.
Ministry of Preaching, The—Jan., p. 42.
 Power in Preaching—July, p. 4.

PROPHECY
 Daniel in the New Testament—Nov., p. 27.
 Feet of Clay, The—Feb., p. 19.

PUBLIC RELATIONS
 Anonymous Worshipers—Jan., p. 48.
 Public Relations in Missionary Evangelism—Jan., p. 16.
 Stunted in the Spotlight—July, p. 48.

PULPIT—POINTERS FOR PREACHERS
 Passionless Theology—March, p. 48.
 "Prove This Wrong, Otherwise It's Correct"—Sept., p. 48.
 Reverent Research—March, p. 48.
 "So Shall It Be"—Aug., p. 48.
 Telephone Samaritans—Feb., p. 40.
 With All Deliberate Speed!—Feb., p. 48.

RELIGIONS
 A First Step in the Christian Approach to Islam—Sept., p. 12.
Backgrounds of Dispensationalism—June, p. 40.
Case of Christianity, The—March, p. 34.
George Fox and the Quakers—Jan., p. 40.
Handbook of Denominations in the United States—Sept., p. 42.
 Our Friends the Baptists—June, p. 34.
 Our Friends the Congregationalists—Oct., p. 37.
 Our Friends the Disciples of Christ—Aug., p. 36.
 Our Friends the Lutherans—Sept., p. 36.
 Our Friends the Methodists—Dec., p. 32.
 Our Friends the Presbyterians—July, p. 39.
 Our Protestant Friends—May, p. 30.
 Protestant Episcopal Church—Anglican—Nov., p. 38.
Story of Religions in America, The—May, p. 21.

RELIGIOUS WORLD TRENDS
 Church Is on the March, The—Jan., p. 5.
 Has the World Been Warned?—Nov., p. 48.
 Monotonous Conformity—May, p. 48.
 Religious World Trends—Jan., p. 4.
 Rock 'n' Roll Version of Christ's Life—July, p. 34.

RESURRECTION
 Breaking the Seal of Death—April, p. 4.
The Cross Through the Open Tomb—Nov., p. 26.

RETIREMENT
 A Veteran in Active Retirement—Oct., p. 17.
 Problem of Retirement, The—Oct., p. 16.

ROMAN CATHOLICISM
Catholicism and American Freedom—Jan., p. 36.
Primer on Roman Catholicism for Protestants—April, p. 42.
Roman Catholicism and Religious Liberty—Jan., p. 36.
Virgin Mary, The—Jan., p. 36.

SABBATH
The 7th Day—Jan., p. 42.

SABBATH SCHOOL
 Rewards of Leadership, The—Feb., p. 23.

SATAN
 Serpent of Genesis 3:1, The—Sept., p. 31.

SCIENCE
Does Science Support Evolution?—March, p. 34.

SERMONS
Favorite Sermons of John A. Broadus—Oct., p. 42.
Sermons on the Prodigal Son—Jan., p. 40.

SPEECH
 Theological and Other Jargon—July, p. 48.

SPIRIT OF PROPHECY
 Influence of Ellen G. White on Our Work in Australia, The—May, p. 5.
 Testimony of Christ, The—May, p. 7.
 When Will Isaiah 11:6-9 Be Fulfilled?—June, p. 26.

STATE OF THE DEAD
 Walter Martin and the Nature of Man—March, p. 20.

STUDY
 "How Readest Thou?"—Sept., p. 48.

UNCLASSIFIED
 A Motorist's Prayer—Feb., p. 36.
 An Unusual Calendar—March, p. 7.
 Friendships Are Sacred—May, p. 22.
 Message to Israel Radio Program—March, p. 16.
 Protecting Our Members—July, p. 8.

UNITY
 Strength in Unity—May, p. 4.
 Unity in the Ministry—Feb., p. 16.

WORKERS
 Fringe Benefits—Nov., p. 14.
 Supply and Demand—June, p. 7.

YOUTH
 Youth Bible Study Conference—June, p. 24.

CONTRIBUTOR INDEX

A

Allen, Sydney—*Language, Logic, and God*—June.
 Allis, O. T.—*The Covenant of Works*—Dec.
 Anderson, G. T.—*The Minister and Culture*—Oct., Nov.
 Anderson, R. Allan—*Religious World Trends*—Jan.; *Life Only in Christ*—Jan.; *Shared Glory!*—Jan.; *The Passing of an Evangelical Leader*—Jan.; *Anonymous Worshipers*—Jan.; *Secret of Success*—Jan.; *Awakening Interest Among the Jews*—Feb.; *Natural Immortality Unsupported by Hebrew and Greek*—Feb.; *The Simplicity of the Gospel*—Feb.; *Helping Members to Make Their Wills*—March; *Our Editor on the Amazon*—March; *Do We Miss the Significance of Christ's Sacrifice?*—April; *Work for the Deaf*—May; *The Team Spirit in God's Service*—June; *Overused and Unused*—June; *The First Epistle of Paul to the Corinthians*—July; *Our Public Prayers*—Aug.; *Evangelistic Leadership Emphasized in Extension School*—Aug.; *The Modern Use of the Bible*—Aug.; *"Bring the Books"*—Paul—Sept.; *Stewardship and Character*—Sept.; *The Privilege of Stewardship*—Oct.; *"From Greenland's Icy Mountains"*—Nov.; *"Pure Religion . . . Is to Visit"*—Dec.

B

Banks, E.—*A Successful Field School of Evangelism*—Feb.
 Banque, M.—*Child Evangelism Breaks Down Prejudice*—April
 Bargas, F.—*Some Thoughts on Eternal Life*—Aug.
 Beach, B. B.—*Pitfalls of the Ministry*—Sept.
 Beach, P. E. M.—*Public Relations in Missionary Evangelism*—Jan.
 Beach, W. R.—*The Church Is on the March*—Jan.; *Ambassadorship v. Professionalism*—Aug.

Berghem, W. H.—*Our Forgotten Brothers*—Oct.
 Brauer, C. V.—*The Cairo Center*—Nov.
 Brooks, C. D.—*Public Evangelism and the Busy Pastor*—Aug.
 Burman, R. J.—*Church Architecture Today*—March
 Burnside, G.—*Evangelism in Australasia*—March; *Australasian Evangelistic Goal*—Aug.; *Some Books I Can Recommend*—Sept.; *More About the Teachings of the "Radio Church of God"*—Sept.

C

Calkins, H. L.—*Some Books I Can Recommend*—Nov.
 Christian, R. J.—*Spiritual Witness in Our Sanitarium*—Nov.
 Cleveland, E. E.—*Largest Baptism in History of Southern Union*—Jan.; *With All Deliberate Speed*—Feb.; *Tame Talk*—April; *The Spark That Powers*—April; *Dare We Fiddle?*—May; *Mental Reservations*—June; *"Still, Still With Thee"*—July; *Sunday Night Meetings in New York*—July; *1960 Baptisms in Regional Conference*—July; *Inviting Death*—July; *Close That Door!*—Aug.; *"So Shall It Be"*—Aug.; *"The Missing Link"*—Aug.; *Refuge* (poem)—Aug.
 Clifford, F. G.—*The Influence of Ellen G. White on Our Work in Australia*—May; *The Basis of Christian Belief*—June
 Conklin, Dorothy W.—*Thousands of Students Helped by Bible Courses*—Jan.
 Cooper, H. V.—*Some Books I Can Recommend*—April
 Currie, H. C.—*Inspiring Young Men to Enter the Ministry*—Jan.

D

Dart, A. O.—*Where Does the Money Go?*—Feb.; *A Minister Should Tell the Truth*—April
 Davis, T. A.—*Some Books I Can Recommend*—March; *A Worker's Prayer* (poem)—Oct.
 Dombrosky, S. L.—*The Pastor's Treasure Chest*—Jan.
 Dunbar, E. W.—*Assignment: Overseas*—Dec.
 Dunn, N. W.—*Strength in Unity*—May
 Duntton, R. E.—*Some Airatorium Problems Solved*—Dec.

E

Eckert, D. L.—*Posture in Prayer*—Jan.
 Elias, K. A.—*Some Books I Can Recommend*—Dec.
 Esteb, A. A.—*Inspired by Paul* (poem)—Feb.; *Wishing or Fishing?* (poem) March

F

Farag, W.—*"What Think Ye of Christ?"*—Nov., Dec.
 Fearing, A. C.—*Sermons on the Prodigal Son*—Jan.; *Billy Graham Talks to Teenagers*—Feb.; *The Pastor at Work*—Feb.; *Seven Keys to a More Fruitful Ministry*—Feb.; *Standard Lesson Commentary*—Feb.; *The Tale of Two Churches*—July; *Master Preachers*—July
 Figuhr, R. R.—*One Lone Voice*—Aug.; *A Fruitful Field Often Neglected*—Dec.
 Flaiz, T. R.—*Presenting the Gospel Through Medical Ministry*—Feb.
 Ford, D.—*The Apocalypse and the Day of Atonement*—March, April; *Daniel Eight in the New Testament*—Nov.
 Fraser, A. R.—*The Significance of Baptism*—Oct.
 Friesen, G. P.—*What Has Happened to the Singing Evangelist?*—Nov.

G

- Gooding, Wilma—Influence—May
Gordon, A. E.—“I Like Our Pastor
But . . .”—Feb.
Guenther, C. E.—Who Is a Good Neighbor?—May

H

- Hannum, H. B.—The Humble Hymn—Feb.
Hardinge, Mrs. L.—The Minister's Wife and Her Home—March; The Minister's Wife and Her Husband—April; The Minister's Wife and the Church—May
Havner, V.—Last Call to the Churches—March
Haynes, C. B.—On Being a Preacher—June
Hempe, Margaret—A Happy Minister's Wife—Aug.
Heppenstall, E.—The Hour of God's Judgment Is Come—June; July
Hilgert, E.—Some Books I Can Recommend—Feb.
Hitten, S. S.—Some Books I Can Recommend—Oct.
Holley, W. R.—The Short Evangelistic Campaign—July
Humann, E. S.—Some Books I Can Recommend—July

J

- Japas, S.—The Bible Course and the Soul-winning Campaign—Oct.
Johns, A. F.—The Feet of Clay—Feb.
Johnston, B.—An Evangelistic Field School at Emmanuel Missionary College—July

K

- Keough, G. A.—A First Step in the Christian Approach to Islam—Sept.; Andrews University Extension School, Beirut, Lebanon—Nov.
Keough, G. D.—Divine Forgiveness—May
King, G. D.—Supply and Demand—June
Kinman, B. F.—Some Books I Can Recommend—June
Kleuser, Louise—*George Fox and the Quakers*—Jan.; *Biblical Revelation and Inspiration*—Feb.; *Expanding Methods in City Evangelism*—April; *Our Protestant Friends*—May; *The Death and Resurrection of Christ*—May; *Josephus, Complete Works*—May; *Baker's Dictionary of Theology*—May; *The Comprehensive Bible Concordance*—May; *Principles of Biblical Hermeneutics*—May; *Dake's Annotated Reference Bible*—May; *The Newberry Study Bible*—May; *Our Friends the Baptists*—June; *Candles in the Night*—No. 1—June; *Backgrounds of Dispensationalism*—June; *Brothers in Christ*—June; *A Call to Faith*—June; *Our Friends the Presbyterians*—July; *Christ Our Example*—July; *The Windows of Heaven*—July; *Our Friends the Disciples of Christ*—Aug.; *The Golden Oil*—Aug.; *Our Friends the Lutherans*—Sept.; *Candles in the Night*, No. 2—Sept.; *The Epistles to the Corinthians*—Sept.; *Letters to Young Churches*—Sept.; *Handbook of Denominations in the United States*—Sept.; *For One Moment*—Sept.; *Out of My Life*—Sept.; *Our Friends the Congregationalists*—Oct.; *Candles in the Night*, No. 3—Oct.; *Say "Yes" to Life*—Oct.; *Awake, My Heart!*—Oct.; *Favorite Sermons of John A. Broadus*—Oct.; *Candles in the Night*, No. 4—Nov.; *Protestant Episcopal Church—Anglican*—Nov.; *The Gospels Translated Into Modern English*—Nov.; *Devo-*

tional Talks for Children—Nov.; *Our Friends the Methodists*—Dec.; *Great Evangelical Preachers of Yesterday*—Dec.; *The Making of a Minister*—Dec.

Kubo, Sakae—Tempted Like as We Are—Jan.

Kurtz, A.—Review of Basic Principles in Approaching Non-Adventists—May; June; July

L

- Lacey, K.—Progress at the New Gallery Centre, London—Oct.
Loasby, R. E.—Bible Word Studies—Aug.; Fellowship—Dec.
Lorenz, F. A.—*Logos and Lalia*—Nov.
Lowe, H. W.—Frigid Preaching—Feb.; The Moment of Truth—Feb.; Reverent Research—March; Conservation in Evangelism—March; Passionless Theology—March; *The Seven Last Words*—March; *The Cross Still Stands*—March; *The Face of Christ*—April; *Fresh Every Day*—April; *Winnowing the Church*—April; *John Wesley*—April; *Revelation and the Bible*—April; *A Vital Facet in Sickness*—May; *Monotonous Conformity*—May; *The Preacher and His Work*—May; *The Book of Jeremiah*—May; *A Commentary on the Epistle of Jude*—May; *Commentary on I and II Peter and Jude*—May; “All Thy Billows and Thy Waves Passed Over Me”—May; *The Testimony of Christ*—May; *The Bible in Thirty-two Paperbacks*—June; *Power in Preaching*—July; *Theological and Other Jargon*—July; *Stunted in the Spotlight*—July; *What Makes Great Preachers?*—Aug.; *History of Interpretation*—Aug.; “How Readest Thou?”—Sept.; “Prove This Wrong, Otherwise It's Correct”—Sept.; *Slaves or Servants?*—Sept.; “The Only Preaching I Can Do”—Sept.; *Baptismal Qualifications*—Oct.; *Lethargy or Liturgy*—Oct.; *Graham, Wesley, Moody*—Oct.; *God's Pulpit*—Nov.; *Unfolding the Revelation*—Nov.; *Ministerial Reflections*—Dec.; *Has the World Been Warned?*—Dec.
Luccock, H. E.—What Is Theology All About?—Feb.
Ludgate, T. K.—The Wonderful *Charis* of God—Oct.

M

- McLeod, J. P. U.—The Minister's Ally—Oct.
McMillan, J. A.—Fringe Benefits—Nov.
Mansell, D. E.—Walter Martin and the Nature of Man—March; April
Marple, A. C.—The Funeral Service—March
Maxwell, S. G.—Evangelism and the New Africa—May
Moseley, C. E.—The True Thanksgiving Spirit—Nov.
Murray, W. E.—Unity in the Ministry—Feb.; *Our General Church Paper*—Aug.

N

- Nash, G. R.—The Rewards of Leadership—Feb.
Nelson, L. M.—Youth Can Win Souls—Oct.
Nigri, M. S.—Large Baptism in Casa Verde, São Paulo, Brazil—Aug.; “Who Is Sufficient for These Things?”—Dec.

O

- Odom, R. L.—Herbert W. Armstrong and His “Radio Church of God”—March; Did Christ Stay in the Grave Exactly 72 Hours?—April

Olson, A. V.—“The Priestly Application of the Atoning Act?”—May; When Will Isaiah 11:6-9 Be Fulfilled?—June

Olson, L. H.—Evangelism in South America—Aug.

Osborn, J.—Breaking the Seal of Death—April

P

- Pease, N. F.—How Much Education Should a Minister Have?—Sept.
Pierson, R. H.—God's Men for God's Hour (poem)—Aug.; “Never Lose Your Sense of Urgency”—Nov., Dec.

R

- Read, W. E.—The Son of God, the Messiah—March; The Serpent of Gen. 3:1—Sept.
Reeves, C. A.—The Psychology of Decision in Public and Personal Evangelism—Sept.
Reiber, M. T.—The Pastor and the Sabbath School Class—Oct.
Richards, C. T.—The Problem of Fear in the Christian Experience—Feb.
Roberts, H. L.—A Veteran in Active Service—Oct.
Robertson, J. T.—Dedicating the Church—Nov.
Roefelt, E. E.—The Incarnation—Its Deeper Meaning—Dec.

S

- Sage, R.—A God Upon Whom We Can Depend—Aug.
Salom, A. P.—“Agapé”—the Great Christian Virtue—Sept.; The New English Bible: A Preliminary Critique—Oct.
Schubert, W.—Love for the Lost—May; What We Do We Must Do Quickly—July.
Short, J. J.—The Dilemma of Adventist Medicine—Aug.; The Problem of Retirement—Oct.
Sims, W. H.—Let the People Sing!—Jan.
Smith, Helen—Building Up Church Attendance—Sept.
Stevenson, G. S.—Some Books I Can Recommend—Aug.

T

- Tippett, H. M.—Do We Provoke the Lord to Jealousy?—March
Tuland, C. G.—Tithing in the New Testament—Oct.; Church Leadership and Leaders—Dec.

V

- Vandeman, G. E.—From TV Screen to Harvest—April; How to Bring to Harvest the Screen Contacts Made by It Is Written—May; Evaluation of It Is Written Decision Films—Aug.

W

- Walworth, Ruth—The Wreckers (poem)—July
Weeks, H. B.—Some Books I Can Recommend—May
Westphal, H. J.—The By-products of Evangelism—Sept.
White, E. E.—Why Enoch?—Sept.
White, J. Ina—*Creative Imagination in Preaching*—Aug.
Wittschiebe, C. E.—Andrews University Extension School, South American Division—Aug.
Wright, K. A.—The Greatest Internship—Dec.

Y

- Young, Ethel—The Gateway to Service—Aug.

WIN MORE THAN ONE IN

1 '61

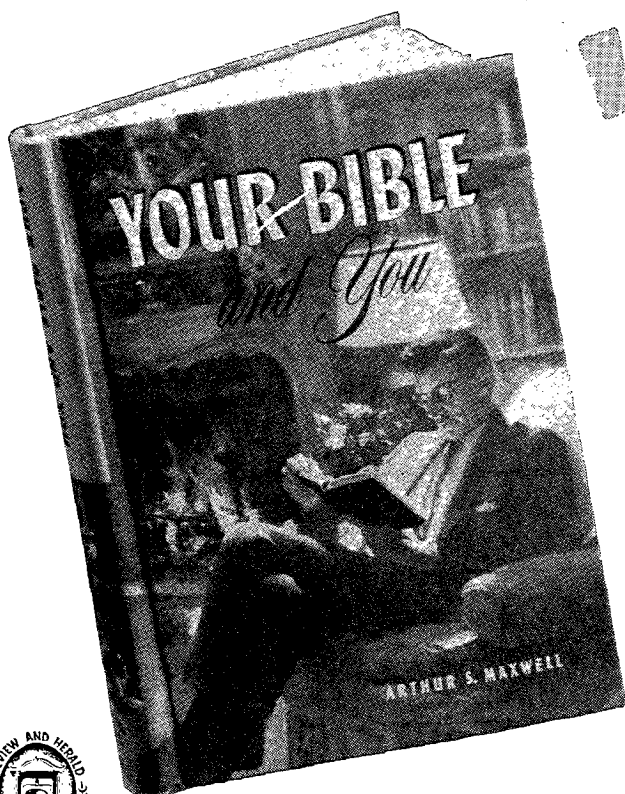

THIS MISSIONARY SPECIAL
IS A PROVED SOUL-WINNER

ONLY



A PRICELESS MESSAGE
IN A MILLION-DOLLAR BOOK



YOU WILL SEE SOULS WON when you give or lend this volume to *relatives *friends *neighbors *business acquaintances and tradesmen *Bible school enrollees *ingathering donors *anyone interested in Bible truth.

YOUR BIBLE AND YOU provides the greatest missionary and evangelistic appeal of all the titles used to date in the special dollar series

THIS COLORFUL FULL-MESSAGE BOOK—

- ★ Contains 448 pages—four-color cover and end sheets—90 full- and double-page pictures in living color by nationally known illustrators—plus many smaller full-color pictures
- ★ Is divided into seven sections for study and reading convenience—complete with table of contents and index
- ★ Convincingly covers the major Bible doctrines held by Seventh-day Adventists
- ★ Discusses themes vital to every seeker after truth
- ★ Touches life on the level of the everyday, with pictures and text beamed to the modern reader
- ★ Unveils the startling present and future events of Bible prophecy
- ★ Outlines God's patterns for peace and personal power

ORDER TODAY FROM YOUR BOOK AND BIBLE HOUSE

_____ Church Missionary Secretary or
_____ Book and Bible House

Please send to address below

_____ YOUR BIBLE AND YOU, Missionary edition

@ \$1.00 each _____

State Sales Tax where necessary _____

Postage (less than 10 volumes; see note) _____

Total enclosed _____

Note: 10 volumes or more to one address postpaid in the U.S.A. Less than 10 volumes, add 15c postage for first volume and 5c for each additional book. Canada and foreign, add 12c postage and insurance for each book ordered.

Name _____

Address _____

City _____ Zone _____ State _____

IS A FRIENDLY VOLUME—WARM WITH THE LOVE OF GOD

BOOKS -- For Your Library

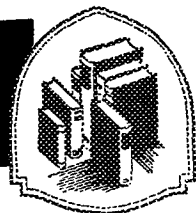

Great Evangelical Preachers of Yesterday, James McGraw, Abingdon Press, New York, 159 pages, \$2.75.

James McGraw is professor of preaching and pastoral ministry at Nazarene Theological Seminary, Kansas City, Missouri. He is also an experienced pastor. In his book the author has covered 24 preaching giants from Wycliffe's time to G. Campbell Morgan of the early twentieth century. His chapters are brief but they crowd in the inspirational and practical preparation of the preaching ministry in its various facets.

The pithy, pointed statements of many biographers are well summarized, so that the book itself becomes a simple analysis of the genius behind these successful preachers. Preaching is elevated into an artful skill, with a strong emphasis on both doctrinal and expository preaching. Here is basic knowledge of ministerial methods that have not become antiquated in present-day soul winning. Many of the men mentioned above moved large audiences for Christ in their day, and their power stimulates every evangelistic-minded pulpiteer today.

Great Evangelical Preachers of Yesterday provides a most useful bibliography. Another value is the frequent technique of effective sermon building, all in down-to-earth style. The simplicity of sermon technique is frequently stressed by means of examples.

To denominational workers who have in recent years basked in our local lectureships, this book will provide continuing inspiration. We recommend it also to college Bible teachers for their classwork.

LOUISE C. KLEUSER

Assignment: Overseas, by John Rosengrant and others, Thomas Y. Crowell Co., New York, 1960, \$1.95.

Americans or other nationals planning to go overseas and desiring to be helpful, effective residents or visitors in other lands, will find *Assignment: Overseas* of tremendous help. It is especially applicable to American missionaries and Christian tourists toward whom the book is beamed and who recognize that their religious faith must be the basis for their way of life.

This book will not solve all the problems but it can certainly assist every reader in becoming sensitive to the way of life in other cultures and societies. *Assignment: Overseas* contains facts, ideas,

suggestions, and the considered opinions of a variety of experts, which should substantially help those who are going overseas and wish to be properly oriented.

The book had its origin in lectures given at the Institute on Overseas Churchmanship and was designed especially for people planning to embark on overseas assignments for government, business, technical assistance organizations, and service organizations. It directs the thinking of such people into areas such as—

1. The tensions, problems, and dilemmas with which the individual will be confronted as an American and as a Christian in his relationships with other people abroad.

2. Our belief as Christians about the worth and dignity of man wherever he may be found.

3. The uniqueness of the Christian faith.

4. The making of an intelligent Christian witness in everyday relationships and personal associations overseas.

Assignment: Overseas gives evidence of careful and sensitive editing. It merits a wide reading by ministers and all concerned with our worldwide movement.

E. W. DUNBAR

The Making of a Minister (the autobiography of Clarence E. Macartney). J. Clyde Henry, Channel Press, Inc., Great Neck, New York, 1961, 224 pages, \$3.00.

J. Clyde Henry introduces the autobiographer to his readers. The life, talents, pulpit strength, and pastoral appeal of this minister are referred to as a part of the great American heritage. Its flavor is different from some other national backgrounds. It shows the spiritual and civic development of a man who made a success of large city pastoring in America. One of the book's contributions is a firsthand evaluation of the Harry Emerson Fosdick issues—the controversy between the modernists and liberals. In this Clarence E. Macartney and J. Gresham Machen hold up the fundamentalist standards.

LOUISE C. KLEUSER

GOSPEL TENTS

STEEL-CLAD TABERNACLES

SMITH MANUFACTURING CO., DALTON, GA.

Over 50 Years in Business

For 1962—the beautiful

Christian Home Calendar

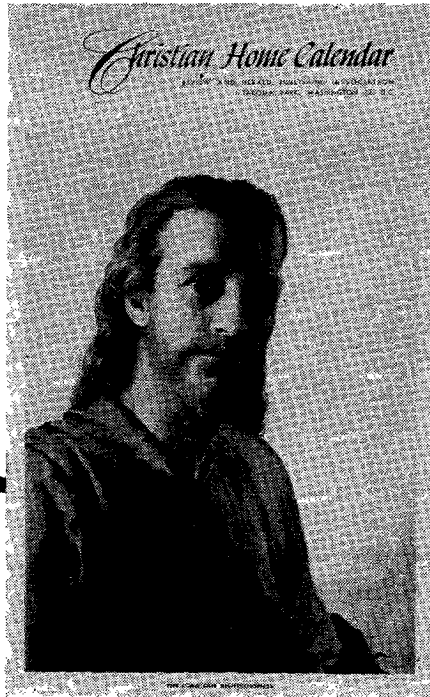

Especially designed to fit the needs of the Christian home is this popular 1962 calendar. Only paintings of high-quality art in beautiful colors have been selected for each month of the year, and in addition there is a large reproduction on the cover, suitable for framing.

PRICE **50** CENTS

- ★ Favorite daily scriptures ★ Prayer poems ★ Monthly missionary topic ★ Sunset tables
- ★ True Sabbath bears witness in glowing red ★ Beautifully reproduced in full colors.
- ★ Size 11" by 18½" ★ A favorite in Seventh-day Adventist homes.

A Gift Suggestion

You will want one for yourself and several to give to friends and neighbors. An ideal thoughtful season's greeting for loved ones.

(If you wish copies mailed direct to names on your gift list, include complete mailing instructions)

..... Book and Bible House
 or Church Miss. Secy.
 Enclosed is \$..... (Add sales tax where
 necessary) This is my order for Chris-
 tian Home Calendars @ 50 cents each.

Name

Street

City Zone

State

Review and Herald Publishing Association
 Periodical Department Washington 12, D.C.

NEWS - From Current Journals

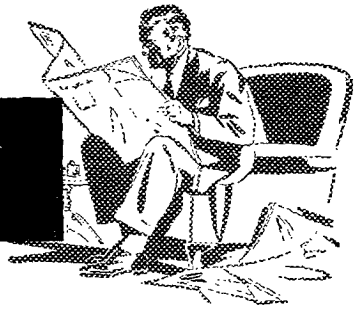

[Unless otherwise credited, the following news items are taken from Religious News Service.]

¶ A "waiting room pulpit" was installed in the concourse of the Milwaukee railroad depot in Minneapolis, Minnesota. A dozen Baptists, Methodists, Lutherans, and Presbyterians were on hand for the dedication, arranged by the Reverend Gustave Edwin Anderson, LaCrosse, Wisconsin, Baptist minister who has made the nation's travelers his "congregation." This was the sixth such pulpit he has placed in railroad and bus depots and airport terminals. "It is the restless traveler who is completely out of touch with God's Word, prayer, Christ, and the support of His work that is our special mission," Mr. Anderson says. The pulpits provided by his organization, known as the Traveler's Spiritual Aid Foundation, dispense religious literature from an enclosed compartment for travelers to read while they wait or ride.

¶ Protestant evangelism in Latin America "is not only necessary but urgent" in view of the "stark reality of the religious situation" in that area, some 600 mission leaders from northeastern United States were told in Silver Bay, New York. Bishop Sante Uberto Barbieri, of Buenos Aires, head of the Methodist Church in Argentina, Uruguay, and Bolivia, declared that even though the great body of Latin Americans may nominally be counted as Roman Catholics, only a small minority are active in any church and the cultural atmosphere is largely secular in orientation.

¶ Cooperation between religion and psychiatry in meeting the needs of the emotionally and mentally ill is improving, and the gap between the two fields—which in some cases amounted to sharp hostility—is closing. That was the recurrent theme of the Second Connecticut Conference on Pastoral Counseling at Hartford, Connecticut. Protestant, Roman Catholic, and Jewish clergymen joined with psychiatrists and psychologists in discussing the application of religion and psychiatric methods in the mental health field. The conference's report was entitled "The Partnership of Clergymen and Psychiatrists."

¶ The Vatican placed restrictions on the use of psychoanalysis for or by Roman Catholic priests and the religious. In a ruling broadcast over the Vatican Radio the Supreme Sacred Congregation of the Holy Office, the Church's highest tribunal on matters of faith and morals, declared that ec-

clesiastics could not practice analysis and could only consult psychoanalysts "for a grave reason" and with permission of their bishop or other superior. The Holy Office also rejected the use of psychoanalysis in testing candidates for the priesthood and religious orders. This issue has been raised in the United States and elsewhere. Ecclesiastical sources in Vatican City noted that the ruling did not constitute a condemnation of psychoanalysis as such, but was a warning against nonconformity with Church doctrine in this sphere, particularly concerning sins forbidden by the sixth commandment. In outlining the reasons for the ruling, the Holy Office referred to "dangerous opinions" concerning violations of the sixth commandment and also concerning the responsibility of human actions.

¶ The Vatican Library has agreed to take back the sum of \$11,000 it had paid for the right to eventual acquisition of certain Dead Sea scrolls. This was announced in a letter sent by Abbot Anselmo Albarada, O.S.B., prefect of the Vatican Library, to Jordan Education Minister Rafiq al-Husseini. The letter was received after Jordan authorities had asked to have the arrangement rescinded, since King Hussein had recently prohibited the export of any of the Dead Sea scrolls. It was disclosed that the University of Manchester, England, also had agreed to take back \$5,600 it had offered for the purchase of portions of the scrolls, and that similar negotiations are under way with five other foreign institutions that sought to acquire fragments.

¶ The Church of Latter-day Saints (Mormon), plans to spend \$6.9 million on new churches in Australia, it was announced by Bruce R. McConkie, of Salt Lake City, Utah, newly appointed president of the church's Southern Mission in Australia. Noting that there are about 10,000 Mormons in that country, Mr. McConkie said his denomination is building the new churches because it "has faith in Australian youth."

¶ A mosque to serve London's 80,000 Moslems is being erected on the grounds of the Islamic Cultural Centre in London at an estimated cost of \$1.4 million. Because of the growing number of Moslems coming to Britain from India and Pakistan, plans are under way to build mosques in other large cities such as Birmingham. Contributions for the London mosque have been received from Moslem leaders in various countries including India, Egypt, Tunisia, and Pakistan.

Companions in Service

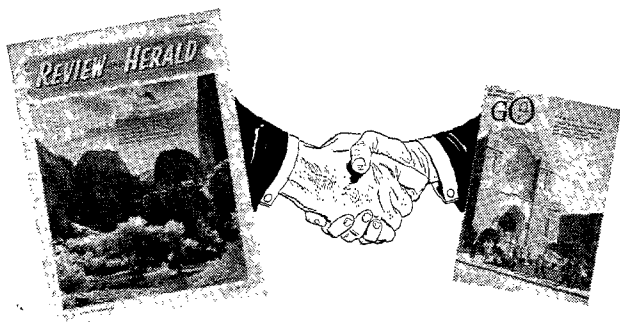

THE "REVIEW" WILL INSPIRE YOU

"GO" WILL SHOW YOU HOW

"GO has become one of the indispensable magazines of the church for inspiring and instructing our laymen in the art of soul winning. GO is helping to prepare our church members to play their part in the loud cry of the message and in the finishing of the work."



R. R. Figuhr, *President
General Conference*

Special RATE GO and REVIEW COMBINATION

12 issues

52 issues

One Year Only \$5.85

ORDER BLANK

Enclosed find \$ _____

Church Missionary Secretary or _____ Book and Bible House

Please enter subscriptions as checked below

- GO—1 yr. \$1.90. Extra-postage countries, 25c additional.
 REVIEW—1 yr. \$3.95. Extra-postage countries, \$1.00 additional.
 Combination GO—REVIEW, \$5.85.

NAME _____

Street _____

City _____ Zone _____ State _____

Review and Herald Publishing Association, Washington 12, D.C.

ORDER FROM YOUR BOOK AND BIBLE HOUSE

¶ Johannes Gutenberg, printer of the first Bible, is to be honored on a new eight-pfennig postage stamp for use in West Germany and Berlin. He is one of the famous Germans selected for this series. It is the first time Gutenberg has been honored on a German postage stamp. The United States honored him with a stamp issued in 1952, the four hundredth anniversary of his invention of printing from movable type.

¶ On August 7, high above the earth on his orbiting flight around the world, Russian cosmonaut Gherman S. Titov breathed exultantly into his radio microphone: "I am Eagle . . . I am Eagle." He didn't know it, but his spaceship had crashed head-on into the Southern Baptists' Biblical quotation for the day, one selected nine months before. It was Obadiah 4: "Though thou shalt exalt thyself as the eagle, and though thou set thy nest among the stars, thence will I bring thee down, saith the Lord." Obadiah's words were delivered to the Edomites who, proud and haughty, had believed themselves to be above the reach of God. The quotation for August 7 was selected in December as the Southern Baptist Training Union's daily Bible passage. Lest readers apply the passage solely to the Russian "Eagle," Donald F. Ackland, editor of *Open Windows*, Southern Baptist devotional quarterly, said that one must "remember the eagle is the symbol of the United States also."

¶ Greek Minister for Justice Constantine Kallias issued a directive in Athens to all district prosecutors, ordering them to enforce constitutional provisions banning the translation and publication of the Bible in any language other than the original Greek. The national constitution forbids the translation of the Scriptures into popular Greek or any Greek dialect or other languages unless special authorization is given by the Greek Orthodox Church and the Ecumenical Patriarchate in Istanbul.

¶ The two hundredth anniversary of the birth of William Carey, famed British Baptist missionary to India, has been marked in Calcutta, India, by many Protestant observances and tributes to the man who spent 41 years spreading Christianity in this country. Born August 17, 1761, in Northamptonshire, England, the preacher, a convert from the Anglican Church, helped found the British Baptist Missionary Society and was its first missionary sent abroad. He arrived in India on November 11, 1793, and spent the remainder of his life there. He died in 1834.

¶ When a firehouse leases space to a church for Sunday religious services, it becomes a "house of worship," the Prince Georges County liquor control board ruled in Seat Pleasant, Maryland. The Central Avenue Baptist church, a suburban congregation which is raising funds for a new edifice, has been meeting in a volunteer fire company building just outside Washington, D.C., for two years. By law, liquor stores must be more than 1,000 feet from a church or a school in Prince

Georges County. The board turned down an application to transfer a package liquor store license to a building a half block from the firehouse. Edward Conroy, attorney for the applicant, strongly protested that the firehouse was erected "primarily for fire-fighting purposes" and that the holding of a religious service there once a week "does not make it a church." However, the board refused the petition when it learned the church may continue to meet in the firemen's hall for several years while it raises funds to construct a building nearby.

¶ Texas' new and unusual Saturday-or-Sunday closing legislation went into effect on November 6. Under its provisions merchants will be permitted to determine which day they wish to observe as the Sabbath or closing day. The law is keyed to certain merchandise, notably hardware, which can be sold on only one day of the weekend, Saturday or Sunday.

¶ Lawyers are being libeled by *The New English Bible*, Ontario's Attorney General Kelso Roberts charged in a public address. He spoke to an audience made up largely of lawyers—among them Canada's Prime Minister John Diefenbaker—at the opening of a county courthouse. The attorney general said the new version of the Bible substituted the word *lawyer* for *scribe*, so that the profession is linked consistently to Pharisees. He cited one passage: "Alas you lawyers and pharisees, hypocrites . . ." "This," said Mr. Roberts, "is the unkindest slur of all." "The word is not related in any way to *scribe*," he said. In ancient times *scribe* was used to designate a public servant who wrote, kept accounts, transcribed manuscripts, and interpreted ecclesiastical works.

¶ Burma's government marked the establishment of Buddhism as the state religion by remitting the death sentences of 98 convicts to life imprisonment. The U Nu regime also reduced the sentences of many other prisoners. Meanwhile, delegations of non-Buddhists who had protested the recognition of Buddhism as the state religion, were refused admission to register their opposition to Premier U Nu. On several occasions the premier had told non-Buddhist groups that their religious rights would be protected under the new law. His remarks were not convincing, according to Christian spokesmen in Burma.

¶ A new decree issued by the government of the predominantly Buddhist island of Ceylon requires all foreign resident Christian missionaries to pay an annual visa tax of \$84. The new tax, designed primarily to discourage the immigration of Indian missionaries, was decreed despite protests by a number of Christian leaders, including Roman Catholic Archbishop Thomas B. Cooray of Colombo. The prelate had a meeting with Prime Minister Mrs. Sirimovo Bandaranaike. However, she pushed aside his objections by stating that if the churches needed the services of non-Ceylonese missionaries, they could meet the visa taxes in the same way that they raise funds for their general activities.

Five Loma Linda LABELS for Sabbath School Investment



G. R. NASH



SECRETARY GENERAL CONFERENCE SABBATH SCHOOL DEPARTMENT, says:
 "The Sabbath School Department indeed appreciates the funds which have come in for our world-wide mission investment program as a result of the Loma Linda label-saving plan, and we commend this worthy project to our people everywhere."



Over \$120,000.00 given to missions

Think of it! Labels and box tops that might have been thrown away and destroyed were saved and turned in for Sabbath School Investment and as a result the Loma Linda Food Company has paid over \$120,000.00 to support the ever expanding mission program. Remember, there will be more money for missions if you save Loma Linda labels.

Is Your Sabbath School Getting Its Share?
 Special designed boxes in which to accumulate labels are available from your Conference Sabbath School Department.

Remember -

 LABELS MEAN PENNIES 

 PENNIES MEAN DOLLARS 

 DOLLARS MEAN

Souls! 

QUALITY FOODS SINCE 1906



OUR DENOMINATIONALLY OWNED FOOD COMPANY

PULPIT -- Pointers for Preachers



HAS THE WORLD BEEN WARNED?

We are prone to prove on the basis of statistics that the task of enlightening the world through the gospel of Christ is almost completed. Statistically that is incorrect, for, as P. E. Hughes points out in *Christianity Today*, July 31, 1961, "1,800 of the world's 3,000 languages are still awaiting the translation of even a part of Holy Scripture," and "1,500 millions of the world's population of 2,900 millions have never heard the message of the Gospel."

We must not be slaves to statistics, it is true, but neither must we ignore the fact that God's work is not finished among men. On every side of us and in every land there is work to be done for God. So colossal is the task, humanly viewed, that it can be done only by hitherto unknown spiritual power. Pentecost will be exceeded; the closing work of the gospel will be marked by greater manifestations of divine power than marked its opening. All this will be done "not so much by argument as by the deep conviction of the Spirit of God" (*The Great Controversy*, p. 612).

This surely implies more consecrated service, more dynamic witness. It may well mean conditions the like of which we have never seen. It must not be assumed that such changes could not mean the deprivation of facilities hitherto considered essential, the loss of liberties we regard as vital, and the disturbance of our soft way of life. Can we expect Pentecostal power without the rugged fortitude, the sacrificial service, and the spiritual unity that faced and conquered the world's hostility following the resurrection?

H. W. L.

"PURE RELIGION . . . IS TO VISIT"

A minister is called to a work of vast proportions. As a pastor he naturally is expected to be a good preacher, and this means he must be a thorough student of the Word. But he must also be a good organizer and know how to keep the church finances sound. Promoting the total church program in all its departments is also essential, and he must make his influence felt as a friend and counselor to the whole community. Yet no feature of all his work is more important than visiting the flock.

Speaking from experience, there is nothing that will strengthen one's ministry so much as his work in the homes of his members, especially those who are sick, or those who for other reasons find it difficult or impossible to attend services regularly.

Recently our attention was called to a member who had developed a heart condition. He had

hoped for a call from the minister, but it was nearly a year before that visit was made. The reason? The pastor said he did not want to "intrude"! That is as amazing as it is alarming. When a person is physically ill, the doctor is certainly not intruding when he calls, and a minister ought to feel the same responsibility as a doctor. Unless for medical reasons it would be unwise for anybody to visit, then above all people the minister should feel the urge to bring assurance and spiritual encouragement.

Other cases similar to this have also been called to our attention. It is good to know that such ministers are few and far between; but even one such is one too many. To visit and pray with the sick, the fatherless, the widows, and all who are in trouble is one of the most sacred privileges ever given to men. Under a well-organized program a pastor can visit twenty-five or thirty homes a day, as well as carry his work of organization and the preparation of sermons. But those visits must be short and well planned. And every visit should leave a spiritual impact upon those visited. In homes and hospitals a minister can often do his most effective work.

Let it never be said of us that we have neglected the poor, the needy, the sick, the discouraged. Our work will not be evaluated by the number of sermons we preach but by the kind of visits we make. "Inasmuch as ye have done it unto one of the least of these my brethren, ye have done it unto me" (Matt. 25:40).

R. A. A.

NEWS NOTE

¶ Religious instruction in all state schools was banned in Warsaw when the Polish Parliament passed an educational reform bill over protests by Roman Catholic deputies. For the first time in Polish history the measure provides legal grounds for completely removing religion from public schools. The bill decrees that Polish children must be taught a "scientific world outlook," making Communistic indoctrination and Marxist study a legal obligation. Under a second law passed by the Parliament, the Communist government will receive title to all public properties, including churches, in the western territories taken over from Germany following the last war. This legislation will require the Polish Catholic Church to give up ownership of about 3,000 churches and parish buildings abandoned by German church bodies in 1945-46.

R. N. S.